

# PRODUCT DATASHEET

## SMART+ WIFI CUBE 50CM Post

SMART+ CUBE MULTICOLOR | Luminaires with WiFi technology



---

### Areas of application

- General illumination
- Gardens
- Patios, balconies

---

### Product benefits

- Easy and quick installation
- Colorful garden lighting with smart and intelligent control options
- Combines the functionality of general lighting and mood lighting

---

### Product features

- Controllable via LEDVANCE SMART+ WiFi App (with minimum Android™ 4.4 or iOS 10.0)
- Controllable via voice control available: Google Assistant or Amazon Alexa
- RGB color control, approx. 16 million color options adjustable
- Dimmable
- Color temperature: 3,000 K (Warm White)
- Network protocol: WiFi
- Type of protection: IP44



## TECHNICAL DATA

### Electrical data

Nominal wattage	10.00 W
Nominal voltage	220...240 V
Mains frequency	50...60 Hz
Nominal current	70.000 mA
Power factor $\lambda$	> 0.5
Protection class	I
Operating mode	Mains voltage

### Photometrical data

Luminous flux	500 lm
Total luminous flux of contained light sources	800 lm
Luminous efficacy	56 lm/W
Color temperature	3000 K
Light color (designation)	RGBW
Color rendering index Ra	$\geq 80$
Standard deviation of color matching	< 6 sdc <sub>m</sub>
Photobiological safety group acc. to EN62778	RG0
Photobiological safety group acc. to EN62471	RG0
Beam angle	205.00 °

### Dimensions & Weight

Length	120.00 mm
Width	120.00 mm
Height	500.00 mm
Product weight	900.00 g



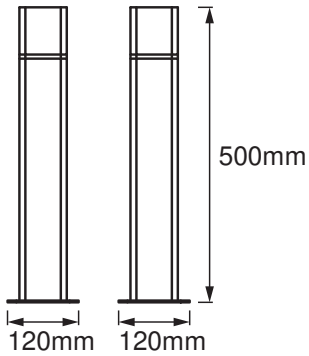

### Materials & Colors

Product color	Dark gray
Housing color	Dark gray
Body material	Aluminum
Cover material	Polycarbonate (PC)
Glow Wire Test according to IEC 60695-2-12	650 °C

### Application & Mounting

Ambient temperature range	-20...+40 °C
Type of connection	Terminal, 3-Pole (L, N, PE)
Type of protection	IP44
Protection class IK (shock resistance)	IK03
Dimmable	Yes
Type of dimming	WiFi
Mounting type	Surface
Mounting location	Ground
Application environment	Outdoor
LED module replaceable	Not replaceable
With light source	No

### Lifespan

Lifespan L70/B50 at 25 °C	25000 h
Number of switching cycles	12500

### Certificates & Standards

Standards	CE / EAC / REACH / RoHS
-----------	-------------------------



Luminaire with limited surface temperature, "D sign"	No
--	----



**Additional product data**

Product remark	Reset settings to default by switching the product on for three seconds and off for three seconds and repeating this five times.
----------------	--

**EQUIPMENT / ACCESSORIES**

- Mounting screws and dowels included
- Control via app or voice control requires compatible Smart home system
- For control via LEDVANCE SMART + WiFi App, a smart phone or Tablet PC is required

**DOWNLOAD DATA**

DOWNLOAD DATA	
	User instruction
	Declarations of conformity

**LOGISTICAL DATA**

Product code	Packaging unit (Pieces/Unit)	Dimensions (length x width x height)	Gross weight	Volume
4058075478169	Shipping box 2	530 mm x 270 mm x 145 mm	2582.00 g	20.75 dm <sup>3</sup>

The mentioned product code describes the smallest quantity unit which can be ordered. One shipping unit can contain one or more single products. When placing an order, for the quantity please enter single or multiples of a shipping unit.

**DISCLAIMER**

Subject to change without notice. Errors and omission excepted. Always make sure to use the most recent release.

