



PC DD PRO sc, 28 – 55 W

TC PRO compact

Product description

- CELMA Energy Efficiency Index
- Nominal life-time up to 50,000 h (at max. ta with a failure rate max. 0.2 % per 1,000 h)
- Large temperature range (for values see table)
- Intelligent Voltage Guard (overvoltage indication and undervoltage shutdown)
- Constant luminous flux irrespective of fluctuations in mains voltage
- For luminaires of protection class I and protection class II
- Automatic start after replacement of defective lamps
- Safety shutdown of defective lamps and at end of lamp life
- Insulation Displacement Connection (IDC) terminal for rapid automatic or manual wiring
- For emergency lighting systems as per EN 50172
- For luminaires with F or M and MM as per EN 60598, VDE 0710 and VDE 0711
- Temperature protection as per EN 61347-2-3 C5e

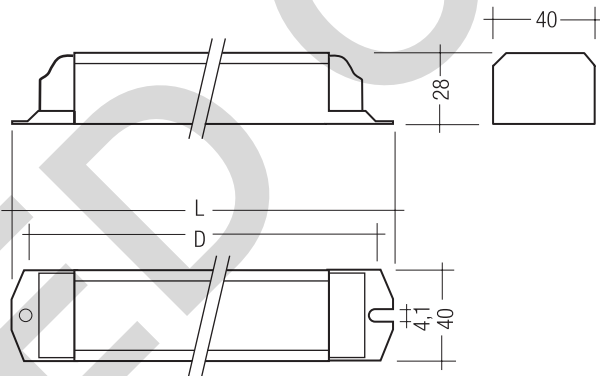

Technical data

AC voltage range	198 – 264 V
DC voltage range	176 – 280 V (Lamp start \geq 198 V DC)
Overvoltage protection	320 V AC, 1 h
Defined warm start	\leq 1.5 s
Operating frequency	\geq 40 kHz
Type of protection	IP20

Ordering data

Type	Article number	Packaging carton	Packaging pallet	Weight per pc.
For luminaires with 1 lamp				
PC 1/28 DD PRO sc	89800004	25 pc(s).	1,250 pc(s).	0.18 kg
PC 1/38 DD PRO sc	89800005	25 pc(s).	1,250 pc(s).	0.18 kg
PC 1/55 DD PRO sc	89800006	25 pc(s).	1,250 pc(s).	0.18 kg

Standards, page 2

Wiring diagrams and installation examples, page 4

Specific technical data

Lamp wattage	Lamp type	Type	Article number	Dimensions L x W x H	Hole spacing D	Lamp power	Circuit power	EEI	Current at 50 Hz		λ at 50 Hz		tc. point max.	Ambient temperature ta
									220 V	240 V	220 V	240 V		
For luminaires with 1 lamp														
1 x 28 W	TC-DD	PC 1/28 DD PRO sc	89800004	150 x 40 x 28 mm	139 mm	25.4 W	28.7 W	A3	0.14 A	0.12 A	0.95	0.95	85 °C	-25 ... 60 °C
1 x 38 W	TC-DD	PC 1/38 DD PRO sc	89800005	150 x 40 x 28 mm	139 mm	34.6 W	39.7 W	A3	0.19 A	0.17 A	0.96	0.96	85 °C	-25 ... 60 °C
1 x 55 W	TC-DD	PC 1/55 DD PRO sc	89800006	150 x 40 x 28 mm	139 mm	53.0 W	60.0 W	A2	0.28 A	0.24 A	0.98	0.98	80 °C	-25 ... 60 °C

Standards:

EN 55015
EN 61347-2-4
EN 61347-2-3
EN 60929
EN 61000-3-2
EN 61547
in accordance with EN 50172

Lamp starting characteristics

Warm start
Starting time 1.5 secs with AC and DC operation
Cathode heating will be reduced after preheat time

AC operation

Mains voltage:
220–240 V 50/60 Hz
198–264 V 50/60 Hz including safety tolerance ($\pm 10\%$)
202–254 V 50/60 Hz including performance tolerance ($+6\% / -8\%$)

DC operation

220–240 V 0 Hz
198–280 V 0 Hz certain lamp start
176–280 V 0 Hz operating range
Light output level in DC operation: 100 %

Emergency lighting

Use in emergency lighting installations according to EN 50172 or for emergency luminaires according to EN 61347-2-3 appendix J.

Instant start after mains interruption < 0.5 s
EBLF ≥ 0.5

Intelligent Voltage Guard

Intelligent Voltage Guard is the name of the new electronic monitor from Tridonic. This innovative feature of the PC PRO family of control gear from Tridonic immediately shows if the mains voltage rises above or falls below certain thresholds. Measures can then be taken quickly to prevent damage to the control gear.

- If the mains voltage rises above approx. 305 V (voltage depends on the ballast type), the lamp starts flashing on and off.
- This signal “demands” disconnection of the power supply to the lighting system.
- If the mains voltage falls below 150 V the control gear automatically disconnects the lamp circuit to protect the control gear from being irreparably damaged.

Smart Heating

Innovative heating circuit. Reduced filament heating after lamp has struck.

Mains currents in DC operation

Type	lamp type	wattage	mains current at $U_n = 220 V_{DC}$	mains current at $U_n = 240 V_{DC}$
PC 1/28 DD PRO sc	TC-DD	1x28 W	0.13 A	0.12 A
PC 1/38 DD PRO sc	TC-DD	1x38 W	0.18 A	0.17 A
PC 1/55 DD PRO sc	TC-DD	1x58 W	0.27 A	0.25 A

Harmonic distortion in the mains supply

Type	lamp type	wattage	THD at 230 V/50 Hz
PC 1/28 DD PRO sc	TC-DD	1x28 W	$< 15\%$
PC 1/38 DD PRO sc	TC-DD	1x38 W	$< 10\%$
PC 1/55 DD PRO sc	TC-DD	1x58 W	$< 10\%$

Working voltage

Type	lamp type	wattage	U_{out}
PC 1/28 DD PRO sc	TC-DD	1x28 W	250 V
PC 1/38 DD PRO sc	TC-DD	1x38 W	250 V
PC 1/55 DD PRO sc	TC-DD	1x58 W	250 V

Ballast lumen factor (EN 60929 8.1)

Type	lamp type	wattage	AC/DC-BLF at $U = 198-254 V, 25^\circ C$
PC 1/28 DD PRO sc	TC-DD	1x28 W	1.00
PC 1/38 DD PRO sc	TC-DD	1x38 W	1.00
PC 1/55 DD PRO sc	TC-DD	1x58 W	1.00

All data are typical values

PC PRO with xitec processor

Is the very latest in lighting management design technology. The lamp friendly warm start is delivering maximum TC-DD lamp life and enables high switching frequency applications. Smallest power loss and new freedom in the lamp design thanks to convincing thermal management.

Energy class CELMA EEI = A2 / A3¹⁾

PC DD PRO sc ignition technology (smart heating) optimises lamp start and ensures no energy is wasted. After the lamp has struck the filament heating is reduced automatically to a defined minimum value. This reduction in filament heating, saves energy, yet maintains the proper operating conditions for the lamp. The lamp is always operated within specification.

¹⁾ according to the EU directives on ecodesign requirements (EC) No. 245/2009 and (EC) No. 347/2010

Ambient Temperature

-25 °C to +60 °C

PC 1/xx DD PRO sc

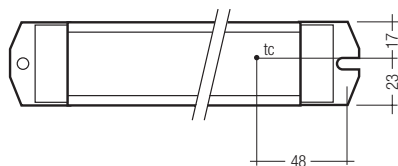

The nominal t_a and t_c point are related to the ballast life duration.

The relation of t_c to t_a temperature depends also on the luminaire design. If the measured t_c temperature is approx. 5K below t_c max., t_a temperature should be checked and eventually critical components (e.g. ELCAP) measured. Detailed information on request.

PC DD PRO sc is designed for an average life-time of 50,000 hours under reference conditions and with a failure probability of less than 10 %. This corresponds to an average failure rate of 0.2 % for every 1,000 hours of operation.

Humidity: 5 % up to max. 85 %, not condensed (max. 56 days/year at 85 %)

Storage temperature: -40 °C up to max. +80 °C

The devices have to be within the specified temperature range (t_a) before they can be operated.

Expected life-time

Type	Lamp type	Lamp power	t_a	40 °C	50 °C	55 °C	60 °C
PC 1/28 DD PRO sc	TC-DD	1x28 W	t_c	65 °C	75 °C	80 °C	85 °C
			Life-time	> 100,000 h	100,000 h	70,000 h	50,000 h
PC 1/38 DD PRO sc	TC-DD	1x38 W	t_c	65 °C	75 °C	80 °C	85 °C
			Life-time	> 100,000 h	100,000 h	70,000 h	50,000 h
PC 1/55 DD PRO sc	TC-DD	1x55 W	t_c	60 °C	70 °C	75 °C	80 °C
			Life-time	> 100,000 h	100,000 h	70,000 h	50,000 h

x = not permitted

Maximum loading of automatic circuit breakers

Automatic circuit	C10	C13	C16	C20	B10	B13	B16	B20
Installation Ø	1.5 mm ²	1.5 mm ²	1.5 mm ²	2.5 mm ²	1.5 mm ²	1.5 mm ²	1.5 mm ²	2.5 mm ²
PC 1/28 DD PRO sc	32	46	66	80	16	23	33	40
PC 1/38 DD PRO sc	20	30	40	44	10	15	20	22
PC 1/58 DD PRO sc	14	20	26	30	7	10	13	15

Wiring advice

The lead length is dependant on the capacitance of the cable.

For safety reasons, the PC DD PRO sc must only be earthed in the case of a safety class 1 luminaire.

Earthing is not required for the device to operate. Connection to earth reduces radio interference.

With standard solid wire 0.5/0.75 mm² the capacitance of the lead is approx. 80 pF/m. This value is influenced by the way the wiring is made. In borderline cases the capacitance must be measured inside the luminaire.

Keep lamp wires short. Lamp connection with twin ballast should be made with symmetrical wiring. Hot leads and cold leads should be separated as much as possible.

Ballast	Terminal	Maximum capacitance allowed	
		Cold	Hot
PC 1/xx DD PRO sc	11, 12	13, 14	200 pF
			100 pF

To avoid the damage of the control gear, the wiring must be protected against short circuits to earth (sharp edged metal parts, metal cable clips, louver, etc.)

Installation instructions

IDC interface

- solid wire with a cross section of 0.5 mm² according to the specification from WAGO

Horizontal interface

- solid wire with a cross section of 0.5–1.5 mm² according to the specification from WAGO
- strip 7.5–8.5 mm of insulation from the cables to ensure perfect operation of the screw terminals

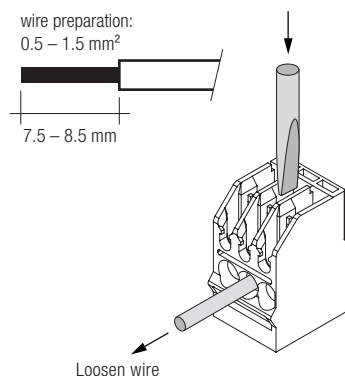

RFI

Tridonic ballasts are RFI protected in accordance with EN 55015. To operate the luminaire correctly and to minimise RFI we recommend the following instructions:

- Connection to the lamps of the “hot leads” must be kept as short as possible (marked with *)
- Mains leads should be kept apart from lamp leads (ideally 5–10 cm distance)
- Do not run mains leads adjacent to the electronic ballast
- Twist the lamp leads
- Keep the distance of lamp leads from the metal work as large as possible
- Connect functional earth, either over the terminal or over the mounting screw of the ballast
- Mains wiring to be twisted when through wiring
- Keep the mains leads inside the luminaire as short as possible

Defective lamp

If a lamp is defective, the ballast switches off and goes into standby. There is an automatic restart once the lamp has been changed.

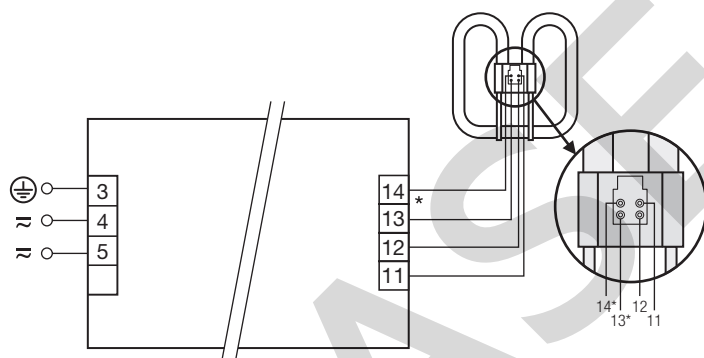

- * leads 13, 14 max. 1.0 m (< 100 pF)
 - leads 11, 12 max. 2.0 m (< 200 pF)
- For luminaires of protection class I: Earthing via ECG casing or earth terminal (according to IEC 60598)
For luminaires of protection class II: No earthing required

PC 1x28-55 W DD PRO sc

Additional information

Additional technical information at www.tridonic.com → Technical Data

Guarantee conditions at www.tridonic.com → Services

Life-time declarations are informative and represent no warranty claim.
No warranty if device was opened.