

Up to 15W

350mA, 500mA and 700mA

CoolLED drivers provide a high performance solution for powering high-brightness LEDs from a mains supply.

The power factor corrected, class II driver has a fully isolated, SELV output delivering up to 15W of power.

The Driver employs new advanced circuitry, leading to a cost effective and efficient solution for low power installations. All CoolLED Drivers have a high efficiency design, which ensures cool operation and long life.

The high efficiency allows operation in 50°C ambient. The compact enclosure is available in Integral (B) and Remote Mount (C) versions. Remote types feature screwless cable clamps.

CoolLED Drivers are open and short-circuit protected and have self-resetting over temperature trip.

Consult the sales office for Conformal Coated, Potted, Hot-Plug and custom versions.



Product Description

- 220-240 Input Voltage
- Isolated SELV output
- Up to 85% efficiency
- Surge protection up to 4kV
- Power factor corrected (0.91)
- Constant current output
- Low LED Ripple Current
- Self resetting thermal trip
- Integral and remote versions
- Double insulated (Class II)

Wiring diagram

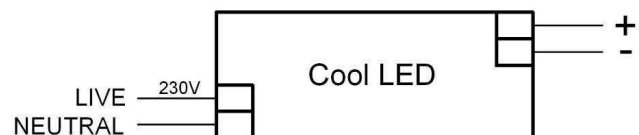

Technical Specification

Mains input voltage	220 to 240V ac RMS Nominal
Mains frequency	50 - 60Hz
Mains surge protection	4kV common-mode 2kV differential
Input-output isolation	3.75kV ac rms
Mains inrush current	45A peak decaying over 20us
Humidity	95% max non-condensing
Thermal trip	110°C - internal self-resetting
Ambient temperature range	-25°C to 50°C
Maximum Tc temperature	80°C
LED ripple current (at full load)	Less than 5%
Terminal blocks	Rising clamp 5mm Pitch
Enclosure	White polycarbonate UL94-V0 rated
Wire size	0.5mm to 1.5mm ²

Case Style	Dimensions	Weight	Box Quantity
B - Integral	97mm x 43mm x 30mm	75g	55
C - Remote	141mm x 43mm x 30mm	95g	55

Tolerance: + or - 0.3mm

Variants

Part number	Current	LED String Voltage	Output power range	Off Load Voltage	Power factor at full load	Efficiency at full load
CLK15-350-240-B/C	350mA (±8%)	8.5V to 43V	3W - 15W	52V max	>0.91	85%
CLK15-500-240-B/C	500mA (±8%)	6V to 30V	3W - 15W	48.5V max	>0.91	85%
CLK15-700-240-B/C	700mA (±8%)	4.2V to 21.5V	3W - 15W	26V max	>0.91	84%

Compliance

Approval	Standards
CE (Europe)	LVD:2014/35/EU; EMC:2014/30/EU; RoHS:2011/65/EU; ECOD/2009/125/EC
ENEC (Europe)	EN61347-1:2008+A1:2011+A2:2013, EN61347-2-13:2014, EN62384:2006+A1:2009
CB (International)	IEC 61347-1:2007 (second edition)+A1:2010 +A2:2012; IEC 61347-2-13:2014 (second edition); IEC 62384:2006 (first edition)+A1:2009
RCM (Australia/NZ)	AS/NZS 61347.1; AS/NZS 61347.2.13:2013; ASNZS-CISPR22+A1; ASNZS 4417.1

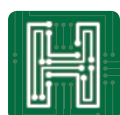

Harvard Technology Ltd.

EU - Tyler Close, Normanton, Wakefield, WF6 1RL, UK Tel: +44 (0)113 383 1000 Fax: +44 (0)113 383 1010

USA - 9171 Towne Centre Drive, Suite #330, San Diego, California, 92122 Tel: (858) 882 - 3844

www.HarvardTechnology.com



SOLUTIONS

Dimensions

B Style

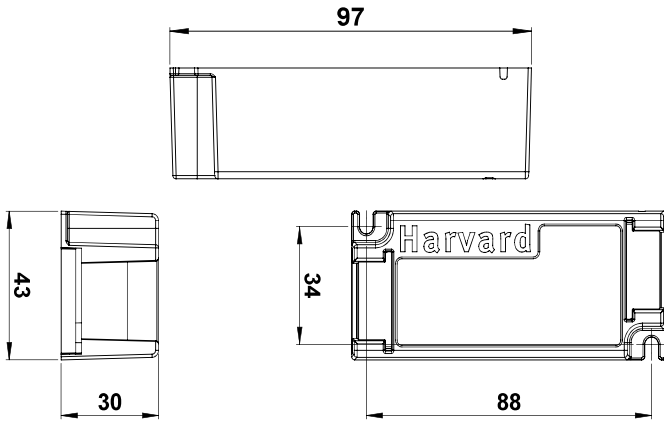

C Style

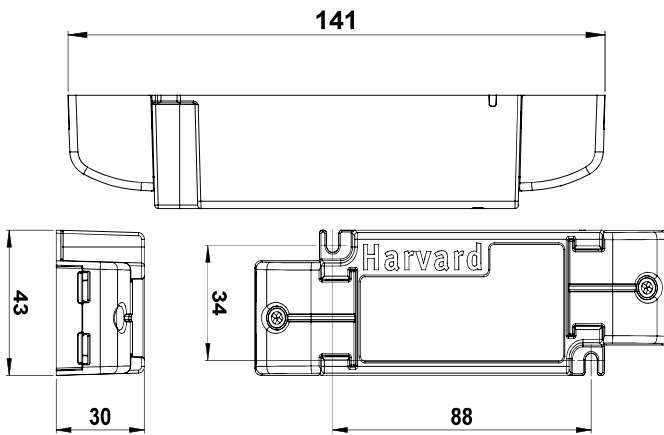
**Harvard Technology Ltd.**

EU - Tyler Close, Normanton, Wakefield, WF6 1RL, UK Tel: +44 (0)113 383 1000 Fax: +44 (0)113 383 1010

USA - 9171 Towne Centre Drive, Suite #330, San Diego, California, 92122 Tel: (858) 882 - 3844

www.HarvardTechnology.com