

MSensor G3 SFI 30 PIR 16DPI WH

Multi-sensor

Product description

- Sensor developed to work with the latest DALI specification
- Monitoring of ambient light and motion detection
- Remote control interface allowing infrared remote control interaction
- Individual adjustment of the parameters
- Power supply via DALI line
- Mounting ring and gasket included to reach IP65 protection
- Wide range of accessories allowing extended application range
- Double terminals for through wiring
- 5-year guarantee

Housing properties

- Casing: polycarbonate, white
- Type of protection up to IP65

Note

- Tridonic MSensor G3 family sensors are developed according to DALI Standard EN 62386-101 Ed.2, also known as DALI-2.

To be able to use the sensor in such installation, an application controller is necessary.

List of approved application controller can be found on our WEB page „[Application controllers MSensor G3.pdf](#)“



Wiring diagrams and installation examples, page 6



MSensor G3 SFI 30 PIR 16DPI WH

Multi-sensor

Technical data

Supply via	DALI
Supply voltage	9.5 – 22.5 V
Current consumption (no LED)	max. 8 mA
Current consumption (with LED)	max. 9 mA
Mounting height ^①	8 – 18 m
Adjustment range position "low"	8 – 12 m
Adjustment range position "high" ^①	12 – 18 m
Mounting opening	70 x 83 mm
Cover size of luminaire	0.75 – 4.00 mm
Detection angle for PIR detection angle "low"	72°
Detection angle for PIR detection angle "high"	60°
Detection range for light measurement ^③	0.5 – 2,000 lx
Min. temperature difference between ambient temperature and detected object	± 4 °C
Ambient temperature ta	-20 ... +50 °C
tc	60 °C
Storage temperature	-25 ... +60 °C
Dimensions L x W x H	99.3 x 86.3 x 46.5 mm
Housing material body	PC polycarbonate
Housing material lens	PE polyethylene
Housing colour body	White (similar to RAL 9010)
Housing colour lens	White
Type of installation	Fitted in luminaires
Type of protection ^②	Up to IP65

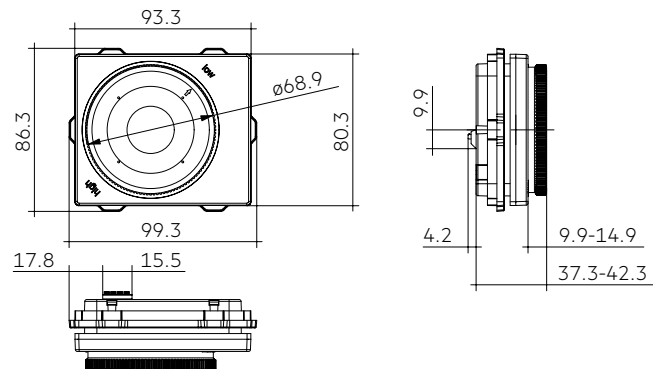

Ordering data

Type	Article number	Suitable for	Packaging carton	Weight per pc.
MSensor G3 SFI 30 PIR 16DPI WH	28002234	Luminaire installation	10 pc(s).	0.105 kg

① For mounting height higher than 16 m it is recommended to use several sensors grouped together in one presence group. As the sensitivity for the detection diameter can not be guaranteed for high over 16 m.

② Depending on the installation type up to IP65 for more details see chapter 31.

③ The measured value at the sensor head corresponds to approx. 3 to 6,300 lux on the surface measured.

ACCES-
SORIES

REMOTECONTROL IR6

Product description

- Optional infra-red remote control
- Switching on and off (On/Off button)
- Dimming (Up/Down button)
- Activation of automatic lighting control
- Setting the threshold control point (Set button)

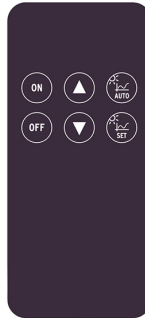

Ordering data

Type	Article number	Dimensions L x W x H	Packaging carton
REMOTECONTROL IR6	28000647	86,5 x 40,5 x 7,2 mm	500 pc(s).

ACCES-
SORIES

Shading Set

Product description

- Shading set consisting of 3 different types of lenses
- Three different covers for the MSensor G3 SFI 30 PIR 16DPI WH give the ability to reduce the detection area in aisle applications
- These covers can be attached or removed from/to the front of the sensor at any time without the need of opening the luminaire
- To have a maximum of flexibility these covers can be attached in every direction of 0°, 90°, 180° and 270°

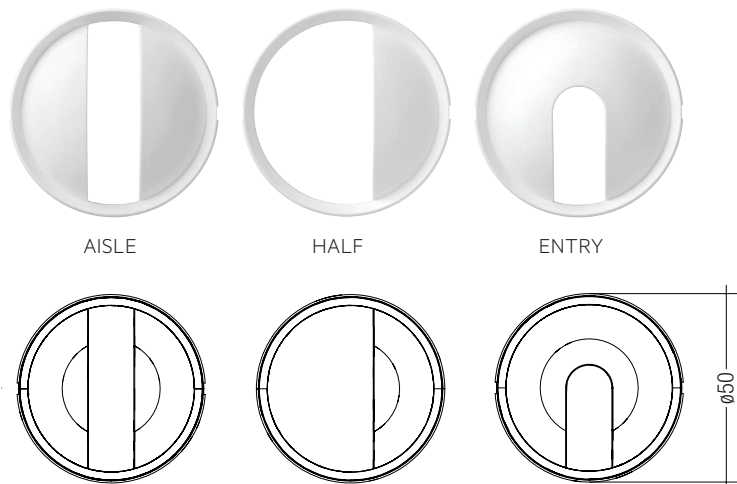

Ordering data

Type	Article number	Packaging carton	Weight per pc.
ACU SHADING AISLE 16DPI highbay	28001658	64 pc(s).	0.002 kg
ACU SHADING HALF 16DPI highbay	28001660	500 pc(s).	0.002 kg
ACU SHADING ENTRY 16DPI highbay	28001659	500 pc(s).	0.003 kg

Mounting box 16DPI

Product description

- Easy adaptation of suspended lighting fixtures to a sensor solution, just by adding one additional hole
- Side entry screw connection in combination with rubber gasket gives a true IP65 protection for industrial applications

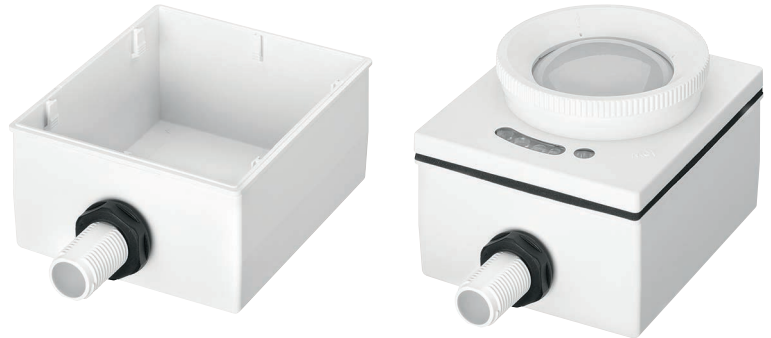

ACU MOUNTING BOX 16DPI HIGHBAY

ACU MOUNTING BOX 16DPI HIGHBAY with sensor

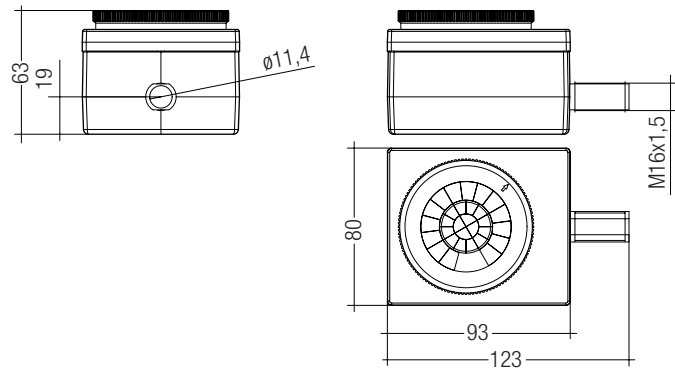

Ordering data

Type	Article number	Packaging carton	Weight per pc.
ACU MOUNTING BOX 16DPI HIGHBAY	28001568	64 pc(s).	0.105 kg

1. Standards

EN/IEC 61347-2-11:2001
 EN 55015:2013
 EN 61000-3-2:2014 Part 3-2
 EN 61000-3-3:2013 Part 3-3
 EN 61547:2009
 EN 62386-101 Ed.2
 EN 62386-103 Ed.1
 EN 62386-301
 EN 62386-303
 EN 62386-304
 EN 62386-332

2. Common

MSensor G3 SFI 30 PIR 16DPI WH is one of the new generation of Tridonic sensors. With this Sensor, the customer gets a sensor for height applications from 8 up to 18 m and a protection against environmental influence up to IP65.

This sensor provides measurement of ambient light, motion detection via PIR sensor and IR remote control input as well as a RGB LED output for signalization.

MSensor G3 SFI 30 PIR 16DPI WH is created for following main applications:

For buildings with mid to high ceiling heights such as:

- Factory buildings
- Storage buildings and warehouses
- Corridors, passages und Garages

3. Installation

- DALI is not SELV.
The installation instructions for mains voltage therefore apply.
- The maximum cable length of the DALI control signal must not be exceeded.
- Please ensure that the detection range of the sensor lies in the lighting area of the controlled luminaires.
- Please ensure that the detection ranges of the sensors do not overlap. This may have influence to the lighting control.
- Heaters, fans, printers and copiers located in the detection zone may cause incorrect presence detection.
- Surface temperature is detected by the sensor.
Clothing or covers which reduce the surface temperature affect the detection.
- To avoid false readings, the sensor should be installed so there is no direct light from the lamp in the detection zone. Reflections can disturb the measurement results as well (e.g. high-bay warehouse of metal shelves).
- To avoid false measurements caused by the light from other luminaires we recommend that the sensor should be located centrally in the luminaire.
- By repeatedly adjusting the zoom (> 10), the IP protection may be impaired.
- Sensor must be installed according to the installation instructions to ensure the IP protection.
- Sensor head is not UV resistant.
- In case of pollution or mechanical damage of the lens, the functionality of the sensor may be limited.

1.1 DALI note



Tridonic MSensor G3 family sensors are developed according to DALI Standard EN 62386-101 Ed.2, also known as DALI-2.

To be able to use the sensor in such installation, an application controller is necessary.

List of approved application controller can be found on our WEB page „[Application_controllers_MSensor_G3.pdf](#)“

1.2 Glow wire test

according to EN 61347-2-11 passed for temperatures up to 750°C.

3.1 Ingress protection

This device contains IP-protection to use it also in applications with the need of protection against dust and water ingress. IP65 protection applies to the front of the sensor whereas the back of the sensor is IP20 rated.

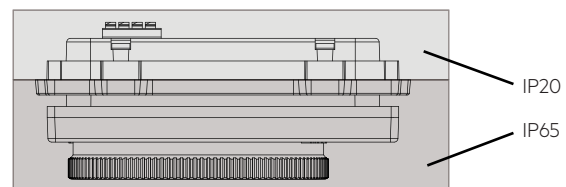

3.2 Wiring

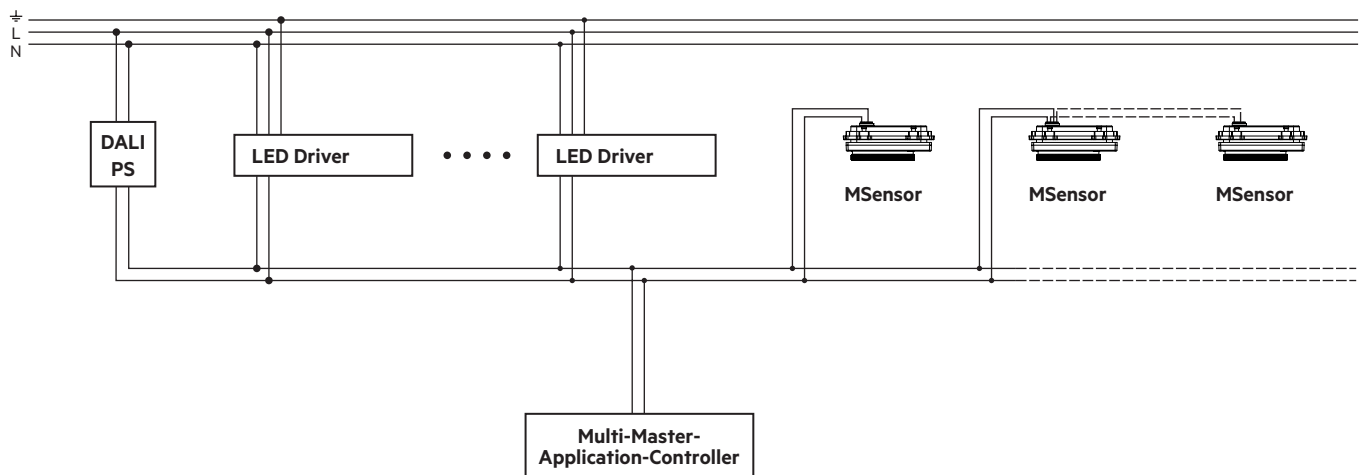

Through wiring:

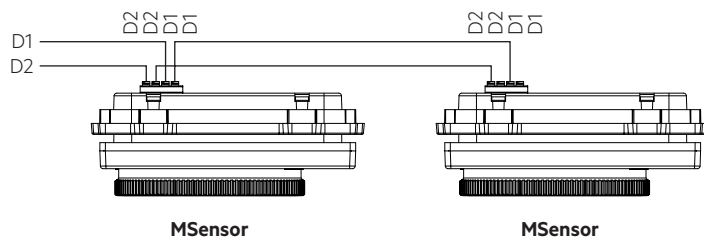

3.3 Cable types and cable cross-sections

Solid wire with a cable cross-section of 0.5 mm² to 1.5 mm².

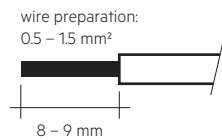

3.4 Mounting variant luminair housing:

Sheet thickness: 1 – 4 mm

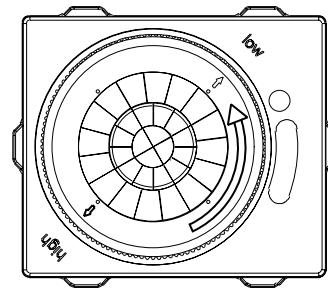
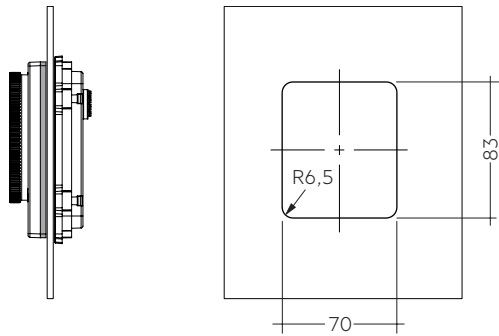

To change from position Low to High rotate lens in arrow direction until it stops at High!

- Arrow shows the zoom position.
- To change the zoom rotate the lens until it stops at High or Low position.
- Positions in between High and Low are not allowed.
- See installation notes!

3.5 Sensor mounting

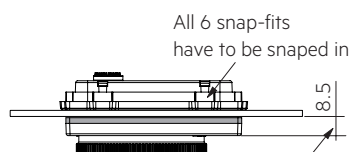
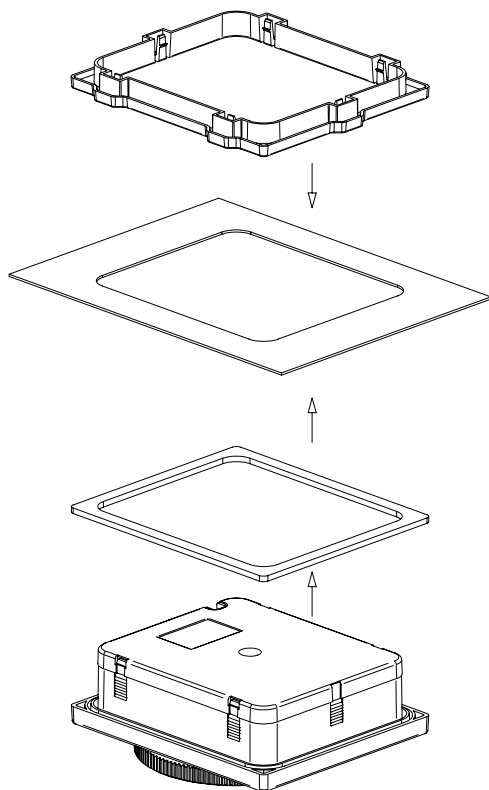

All 6 snap-fits have to be snapped in

To gurantee IP65 the distance between sensor surface and luminaire surface must be less than 8.5 mm

3.6 Shader mounting

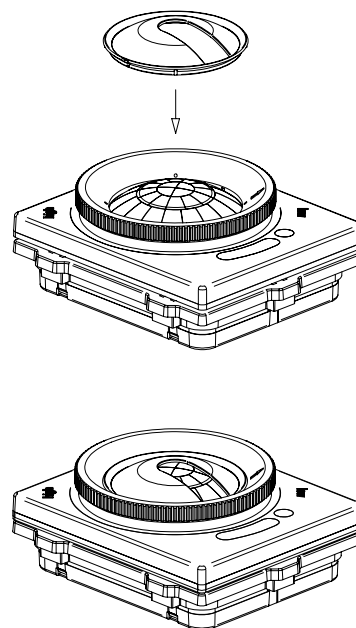

3.7 Mounting box mounting



- The sensor can be installed only once in the mounting box (Sensor snap in permanent)!
- Insert the cable of the sensor before installing.
- There are 2 installation variants possible for the sensor. The sensor can be turned through 180°.

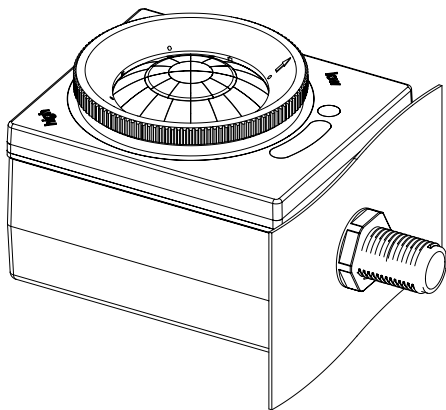
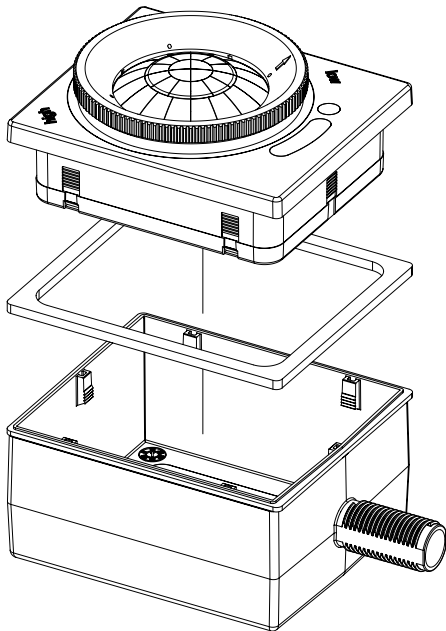

3.8 Mounting box in luminair housing:

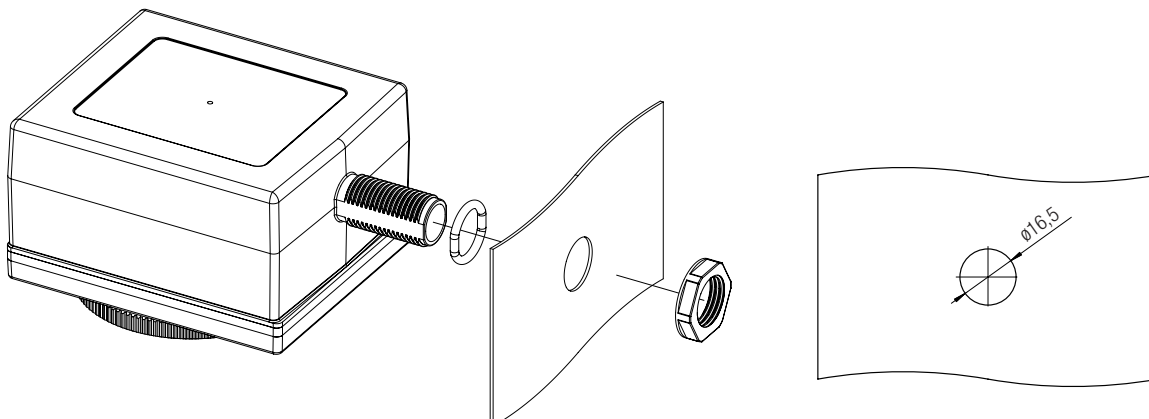

4. Sensor functions

4.1 Light level recognition area

The light measurement has a cone-shaped detection area with a half angle of approximately 6.5°.

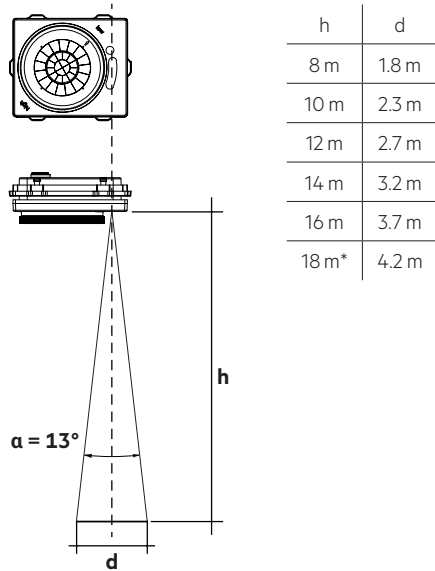

The measurement range is between 1 and 2,000 lx. Measured at the sensor head.

! To be able to measure values < 5 lx in an accurate way it is needed to change integration time of light sensor to 800 ms. Integration time of light sensor is set to 100 ms by default. For values > 5 lx there is no difference in between these measurements.

4.2 Presence / motion detection

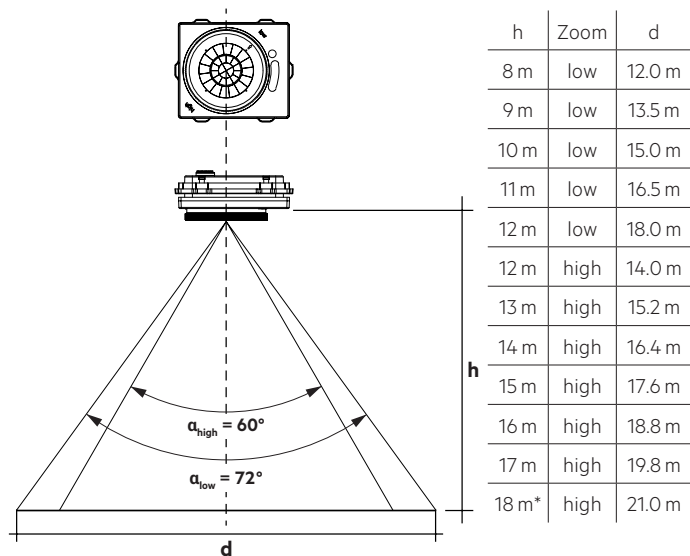

* For mounting heights over 16 m it is recommended to use several sensors grouped together in one presence group. As the sensitivity for the detection diameter can not be guaranteed for heights over 16 m.

4.3 Status LED's

There is a LED built in with three different colours to indicate different status information to the user. This LED is controlled via DALI and from the sensor itself.

! To not have any influence from LED to the light measurement, LED is disabled while light sensor is measuring by default.

The following operating modes can be set for lighting control via the mobile App configuration software:

Active	Constant light control is active.
Inactive	Constant light control is deactivated. The lighting is switched on an adjustable light value.

4.4 Presence / motion detection with shader

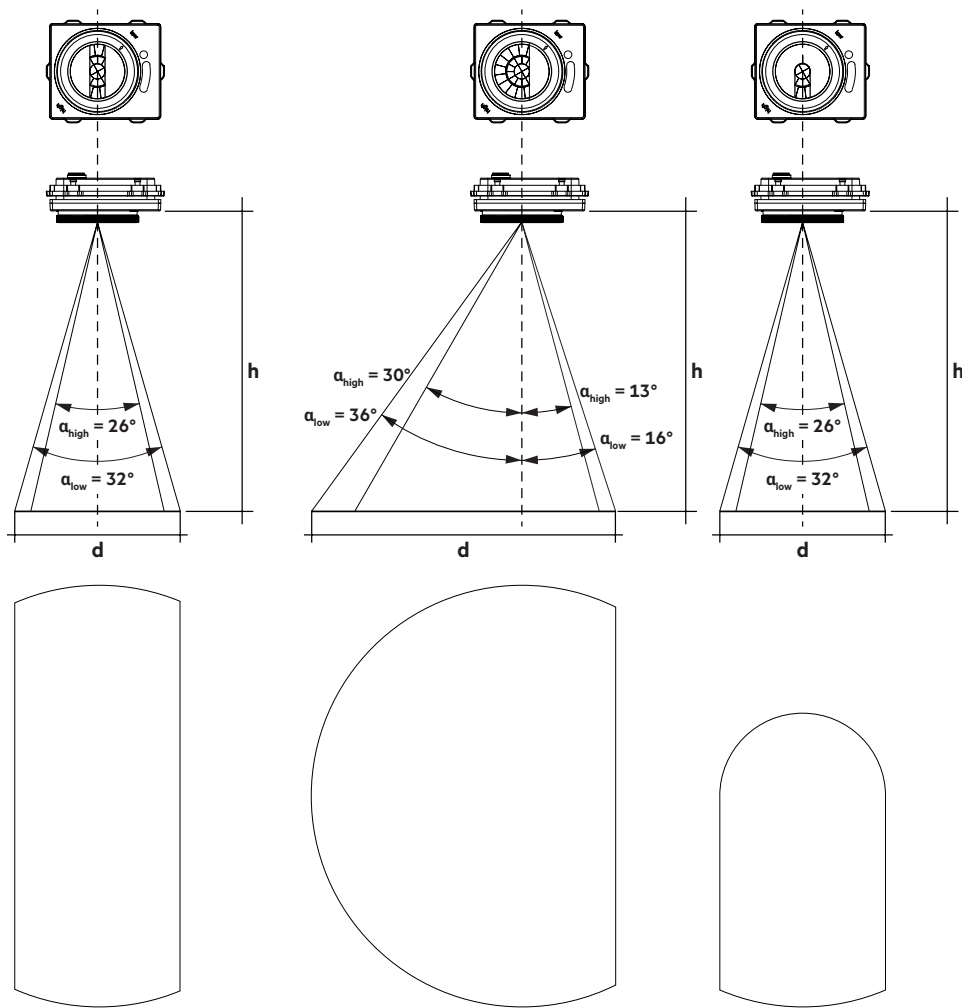

4.5 Application

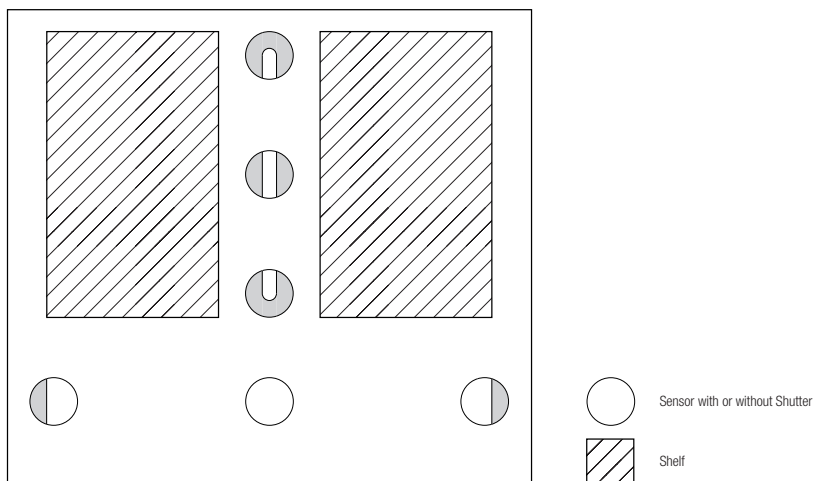

6. Miscellaneous

6.1 Additional information

Additional technical information at www.tridonic.com → Technical Data

Guarantee conditions at www.tridonic.com → Services

Life-time declarations are informative and represent no warranty claim.
No warranty if device was opened.