

DALI-2 CS

Datasheet

Combi Sensor Modul

DALI sensor module
for motion detection,
light detection
and lighting control

Master device:
application controller active

Art. Nr. 86458670

Detection range variants: -15, -O
Colour variants: -W16, -B
Installation type variants: -ZD, -AP



DALI-2 Combi Sensor Multifunctional Sensor Module

Overview

- Sensor Module for DALI and DALI-2 lighting systems
- Movement detection (PIR) instance type 2 (62386-303) and light intensity measurement instance type 3 (62386-304)
- 4 operating modes:
 - Movement triggered
 - Movement triggered with constant light control
 - Constant light control
 - Light control (4 thresholds)
- Operating modes can be changed via scenes and external DALI commands
- Corridor function – second light level before off in case of absence
- Light threshold-controlled regulation for the control of blinds or roller blinds
- The module can be used as a DALI light controller or just as sensor unit for integration in building management systems
- Easy configuration via DALI-Cockpit Software Tool and Lunatone DALI USB interface.
- Multiple sensor modules can be installed within a DALI system.
- Automatic synchronisation of multiple DALI-2 CS modules with the same effective range
- Supply via the DALI bus, no additional power supply needed
- Double terminals for easy installation
- Optimized types for different applications and detection areas (hall, office) available
- Different colour variants: pure white (RAL9010), traffic white (RAL9016), and black.



Specification, Characteristics

type	DALI-2 CS		
article number	86458670	86458670-15	86458670-0
application	standard	hall	office

electrical data:

supply	via DALI signal line (DALI-voltage according IEC62386)
marking terminals	DA, DA
typical current consumption DALI	3.5 mA
power consumption	<100mW
control	DALI

article number	86458670	86458670-15	86458670-0
----------------	----------	-------------	------------

insulation data:

impulse voltage category	II		
pollution degree	2		
rated insulation voltage	250V		
rated impulse withstanding voltage	4kV		
insulation DALI/housing	reinforced isolation		
insulation test voltage	3000Vac		

environmental conditions:

storing and transportation temperature	-20°C ... +70°C		
operational ambient temperature	-20°C ... +60°C	-20°C ... +55°C	-20°C ... +60°C
rel. humidity, none condensing	15% ... 90%		

technical data:

Motion Detection (62386 -303)			
principle	PIR	PIR	PIR
detection range (at >8°C temperature difference)	12m	15m	2.3m / 3m
typical mounting height	8m	12m	3m
zones	92	128	36 / 48
horizontal	±51°	±34,5°	±44°/±90°
vertical	±46°	±34,5°	±44°/±90°
min. temperature difference	>4°C	>4°C	>4°C
details	Figure 1, page 5	Figure 2, page 6	Figure 3, page 6
light sensor (62386-304)	range: 0-2047lux (11bit), resolution: 1lux event:0-2047lux(10bit), resolution: 2lux		
function	configurable		

general data:

protection class	II in intended use
protection degree	IP20
mounting	back box – dimensions see page 4 surface mounted (article number extension „-AP“) – dimensions page 5 suspended ceiling (article number extension „-ZD“) – dimensions page 5
available colours	RAL9010 RAL9016 (article number extension “-W16“) Black (article number extension “-B“)
functional versions	Standard: application controller and instances Version: Integration – only Instances (article number extension “-INT“)

terminals:

connection type	spring terminal connector
wire size solid core	0,5 ... 1,5 mm ² (AWG20 ... AWG16)
wire size fine wired	0,5 ... 1,5 mm ² (AWG20 ... AWG16)
wire size using wire end ferrule	0,25 ... 1,5 mm ²
stripping length	8,5 ... 9,5 mm / 0,33 ... 0,37 inch

standards:

EMC	EN 61547 EN 55015
safety	EN 61347-2-11 EN 61347-1
markings	ENEC-11, CE

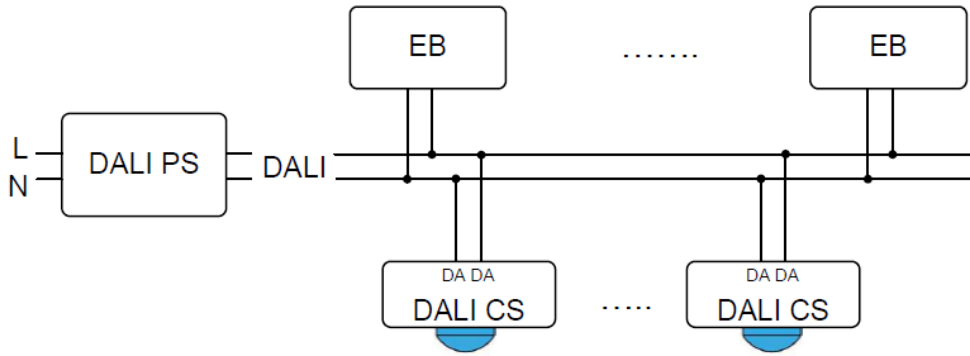

typical application: several sensors on one DALI-line

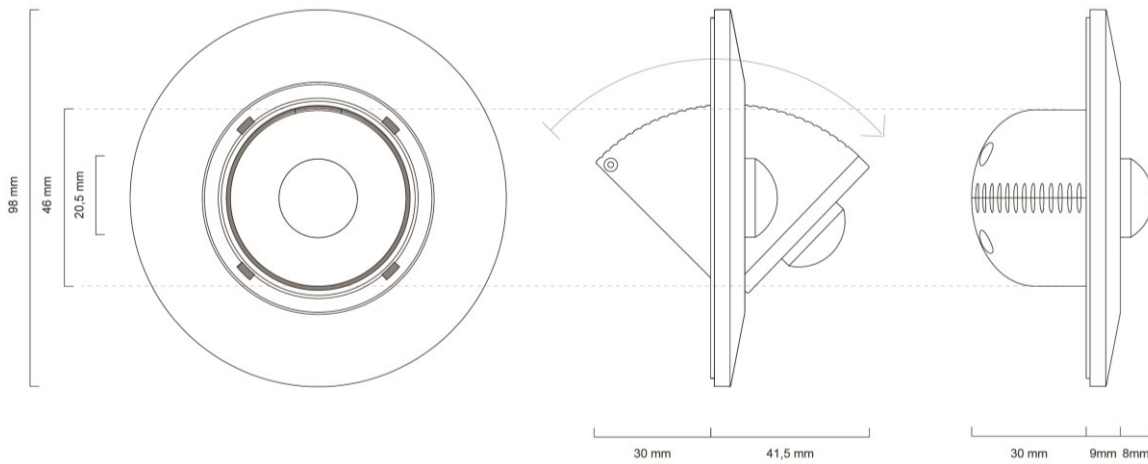

dimensions and space requirements

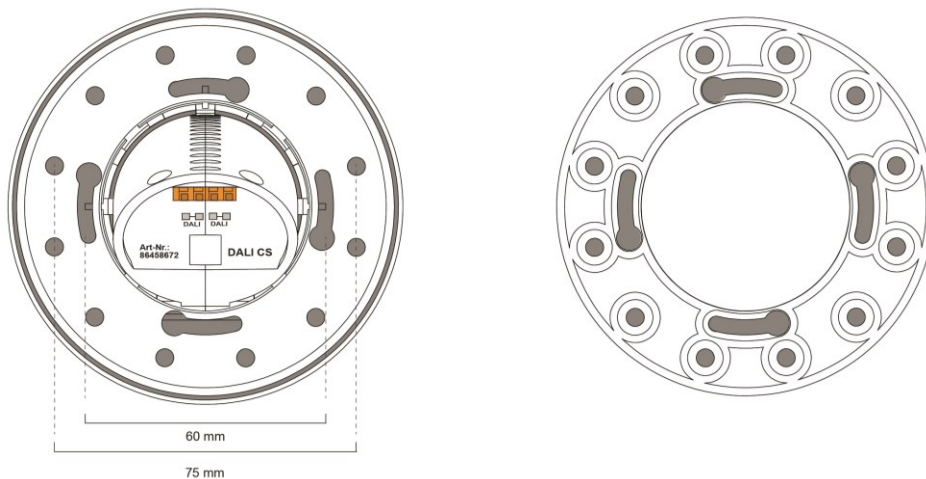

dimensions mounting ring

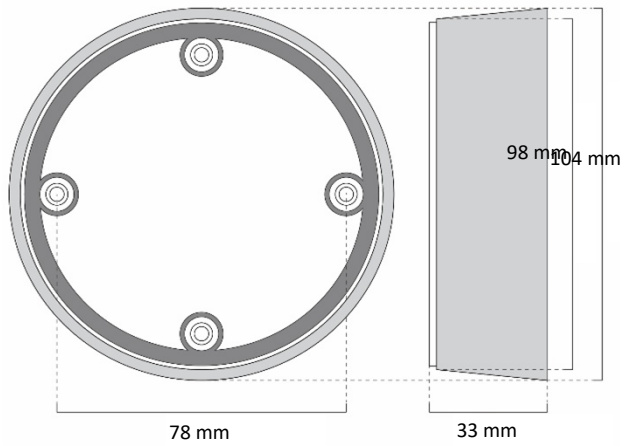

surface mounting
 dimensions accessory
 article number addition „-AP“

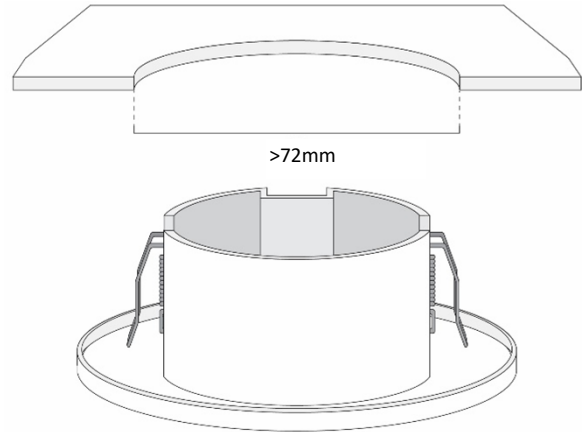

suspended ceiling
 dimensions mounting hole diameter
 article number addition „-ZD“

Sensor types

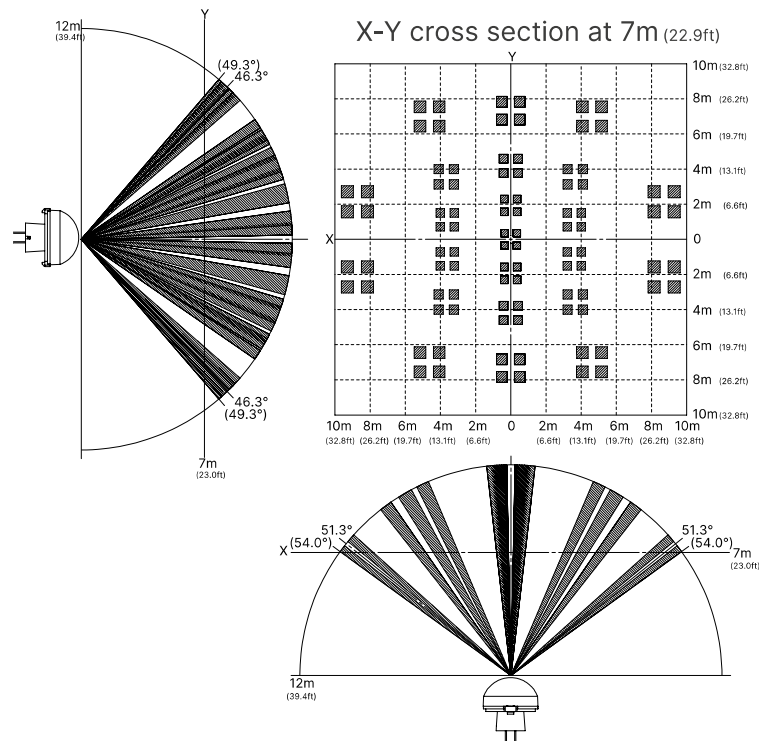

Figure 1 CS standard motion detection (Art. Nr.: 86458670)
 Detection area: X-Y cross section at 7m

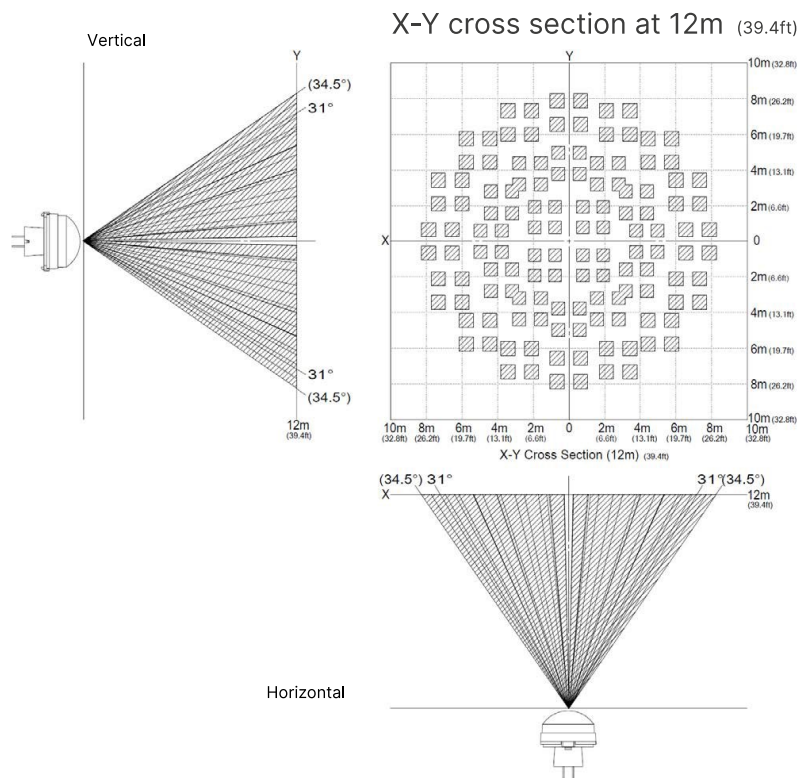

Figure 2 CS-15 hall motion detection (article number addition: 86458670-15)
High density long distance detection type

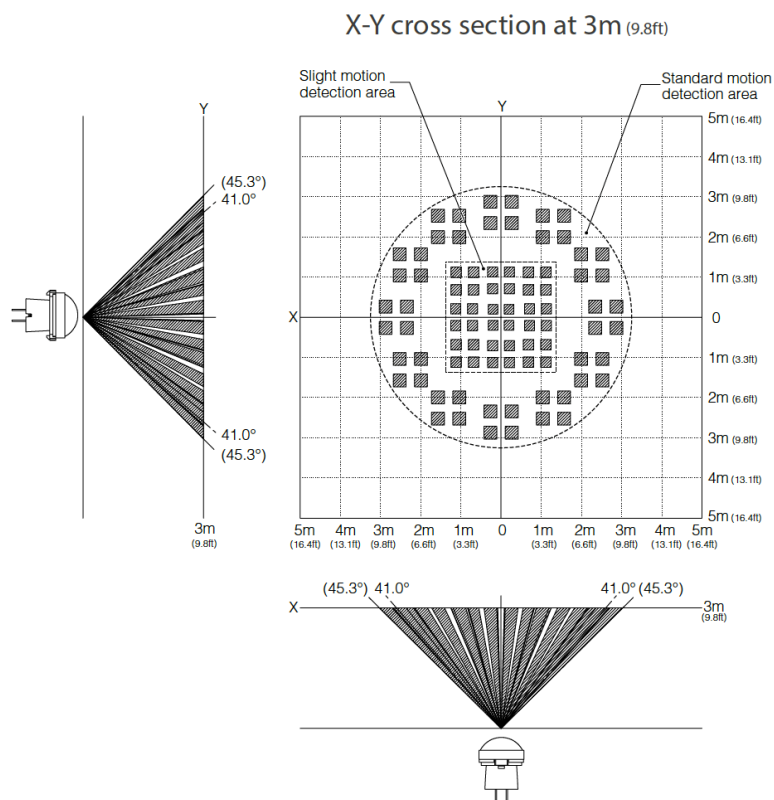



Figure 3 CS-O Office motion detection (article number addition: 86458670-0)
Detection area: X-Y cross section at 3m - The rectangular centre zone is optimized for detecting smallest movements.

Installation

- the DALI-2 CS is directly connected and supplied by the DALI bus. A DALI bus power supply is required.
- The connection to the DALI terminals can be made regardless of polarity.
- The terminals are suitable for wire cross-sections ranging from 0.5 mm² to 1.5 mm².
- back box mounting: installation of the mounting ring directly on the back box. The housing is then simply plugged onto to the mounting ring. The recessed head has sufficient space within the electrical installation box, enabling a flat installation.
- For mounting the sensor on cavity walls or suspended ceilings a version including additional fixtures with spring-clips is available: article number extension “-ZD”.
- Version for surface mounting is available: article number extension “-AP”.
- The CS Module enables alignment to the desired detection area through 360 ° axial rotation and vertical inclination of up to 40 °.
- The wiring should be carried out as a permanent installation in a dry and clean environment.
- Installation may only be carried out in a voltage-free state of the system and by qualified specialists.
- National regulations for setting up electrical systems must be followed.
- The DALI wiring can be realized with standard low-voltage installation material. No special cables are required.
- Only 1 wire may be connected to each terminal. When using double wire end ferrules, the connection capacity of the terminal must be considered.

 **Attention:** The DALI-signal is not classified as SELV circuit (Safety Extra Low Voltage). Therefore, the installation regulations for low voltage apply.

 **Note:** The cross section: the voltage drop on the DALI line must not exceed 2V at maximum length (300m) and maximum bus load (250mA).

Presence Detection

For movement detection a temperature difference between the moving object and environment of at least 4°C is required. Heat sources such as copiers or heaters may have a negative influence on motion detection.

Presence Detection (Standard)

The applied PIR method allows coverage of relatively large areas using only one sensor head. With opening angles of 92° and 102° and a sensor mounted at a height of 5 meters the 92 detection zones cover an area of more than 100m². The distance between sensor and the object of interest should be less than 12 meters, which limits the mounting height to about 8m. See Figure 1 on page 5.

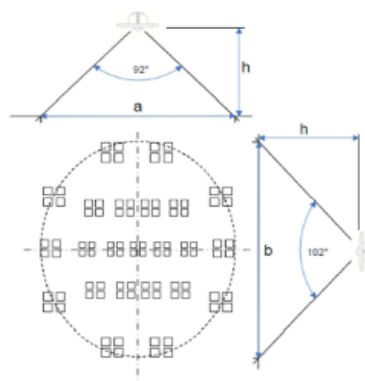

h [m]	a [m]	b [m]	A [m ²]
2,50	5,2	6,2	25,1
2,7	5,6	6,7	29,3
3,0	6,2	7,4	36,2
3,5	7,2	8,6	49,2
4,0	8,3	9,9	64,3
5,0	10,4	12,3	100,4
6,0	12,4	14,8	144,6
8,0	16,6	19,8	257,1

Table. 1 relation of mounting height and detection area

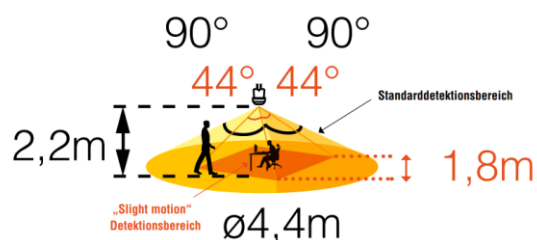

The recommended mounting height is 3m. The distance between the sensor and the object to detect should not be greater than 3.1m.

Presence Detection CS-15

The sensor type „-15“ is suitable for high rooms (e.g. halls) with mounting height up to 12m. The detection range is about 15m. See Figure 2 page 6

h [m]	a [m]	b [m]	A [m ²]
5,0	6,9	6,9	37,1
7,5	10,3	10,3	83,5
10,0	13,7	13,7	148,4
12,0	16,5	16,5	213,7

Table. 2 relation of mounting height and detection area

h [m]	Standard Detektionsbereich			Slight Motion Detektionsbereich	
	a [m]	b [m]	A1 [m ²]	l [m]	A2 [m ²]
2,0	4	4	12,5	1,6	2,56
2,2	4,4	4,4	15,2	1,8	3,24
2,5	5	5	19,6	2	4
3,0	6	6	28,2	2,4	5,76

Table. 3 relation of mounting height and detection area

Presence Detection CS-O

Suitable for office application where detection of slight motion is required e.g. detection of arm movement of a sitting person. The DALI CS-O is tailored to this application and has a sensitive “inner area” and a standard detection “outer area”. The maximum mounting height is about 3m. See Figure 3 page 6

The rectangular central zone is optimized for detection of the slightest motion. The area has an opening angle of 44 ° x 44 ° and 36 detection zones. With a mounting height of e.g. 2.2m, an area of 3.24 m² can be covered. (see table 3).

The outer standard motion detection zone has an opening angle of 90 ° x 90 ° and 48 detection zones. With a mounting height of e.g. 2.2m, an area of 15.2m² can be covered. (see table 3).

Cycle of Motion Detection

The motion detection is always processed according to the following sequence:

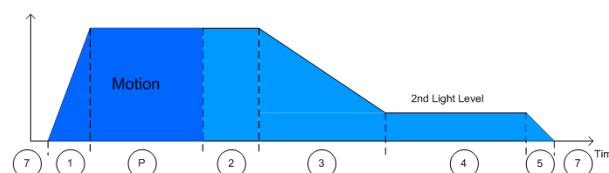

Figure. 4 motion/presence detection sequence

States:

- 1: Fade In Time – dim to 1st light level
 - 2: Hold Time (On-State)
 - 3: Fade Time – dim to 2nd light level
 - 4: 2nd Hold Time (2nd Light Level)
 - 5: Fade Out Time – dim to off
-
- P: Presence detected - retrigger
- 7: Off

If motion is detected the sensor switches to the configured light level. While presence is detected (P) or the hold time is running (2) the light level stays on – either on a fix light level or controlled by a constant light control algorithm.

After the hold time, if not further motion was detected, the sensor changes the light level to the 2nd light level for a defined time (4). This 2nd light level is a user defined value (no constant light control). If motion is detected in this state, the sensor switches to the previous states (1, P). In case no further motion is detected the Off command (7) is sent

HINT: set the “absence level” to a low value, otherwise it could be higher than the light level set by the constant light control.

Steps Nr 1, 3 and 5 control the change between the states: 7/P/2/4/7. Depending on the DALI-commands for each state, the fade time can be used to allow smooth changes.

Light Sensor

Light measurement

All DALI-2 CS versions also include a light sensor. The light sensor measures the reflected illuminance in a range from 0 to 2047 lux. The resolution is 2 lux.

The incident light is rated by the spectral sensitivity of the human eye and thus comparable to the subjective visual perception of brightness.

The incident light is accumulated over the area covered by the lens and can be interpreted as average value in the detection area. A reference to the reflecting surface below the sensor can be established with the help of a reference measurement and adjustable offset value.

Functionality

It is necessary to distinguish between application controller and DALI-2 instances.

The **application controller** gives direct DALI control commands that are immediately executed by the DALI drivers.

DALI-2 instances generate event messages that are interpreted and processed by higher-level control units with DALI connection (e.g. DALI-2 CS in Master Mode, WAGO, Beckhoff, LUNATONE DALI-2 KNX gateway).

The **DALI-2 CS** Art. Nr.: 86458670: can be used as either an application controller: *Master Mode*, or in instance mode: *Slave Mode*. For the application controller all operating modes and setting options described in the document are available.

The **DALI CS Integration** Art. Nr.: 86458670-INT: does not have an application controller and is always in instance mode. The configuration options are described in section *Instances*, on page 21.

Operating Modes

The DALI-2 CS module offers 4 different operating modes: motion control, motion control with constant light control, sole constant light control or light control via light thresholds.

External commands can also be used to influence the operating behaviour of the sensor (e.g. when operated via another control device). The reaction to such interventions is explained in detail for each operating mode.

Operating Mode 1 – motion control

- Movement activates a fixed light level

If movement is detected the time sequence is activated with a user defined fixed light level in State 2 (see Figure. 4 "Motion detection: sequence" on page 8). The light level stays

active until no more movement is detected and the hold time has elapsed. Then the light level will be switched to the 2nd user defined light level.

Additional threshold values can be defined, such that the motion control is only active above or below this defined threshold.

The operating behaviour can be influenced by external on / off / dimming and scene commands. The options for each command are described on page 17

Operating Mode 2 – motion control with constant light control

- Movement activates constant light control
- 2nd light level is user defined and constant

If movement is detected the time sequence is activated with constant light control in State 2 (see figure "Motion detection: sequence" on page 8). The constant light control stays active until no more movement is detected and the "Hold On Time" has expired. Then the light level will be switched to the 2nd light value, which is a fixed user defined value.

Additional threshold values can be defined: such that the motion and light control is only active above or below this defined threshold.

The operating behaviour can be influenced by external on / off / dimming and scene commands. The options for each command are described on page 17

Operating Mode 3 – constant light control

- Constant light Control
- No motion detection

In this operating mode, only the light sensor is used; motion detection is inactive. The constant light control can be switched on and

off with DALI commands (e.g. from a control device such as a DALI light switch).

The operating behaviour can be influenced by external on / off / dimming and scene commands. The options for each command are described on page 20.

Operating Mode 4 – light threshold control

- Light control via light thresholds
- No motion detection

Only the light sensor is used in this operating mode. Both motion detection and constant light control are inactive. 4 light thresholds can be defined which trigger a DALI command on either falling below or exceeding the threshold. 2 of the 4 thresholds can be used to send commands repeatedly. The commands are sent at a user-defined interval until the threshold condition is no longer met.

The operating behaviour can be influenced by external scene commands. The options are described on page 21.

Additional Functionality

Response to external DALI commands

The behaviour of the control in the event of external commands (e.g. by a switch) can be configured with the DALI cockpit. Depending on the operating mode, different behaviours are possible. The options are described later in the document.

The following commands sent to the same destination address (1st address) are interpreted as an **ON command**:

- RECALL MAX
- RECALL MIN
- ON AND STEP UP

DAP>0%
 GOTO SCENE X (if the command was configured to be interpreted as an ON command for the CS)

The following commands sent to the same destination address are interpreted as an **OFF command**:

OFF
 DAP=0
 GOTO SCENE X (if configured to be interpreted as an OFF command for the CS)

Dimming commands: In addition, it can be specified how the motion control or light control should behave when manual dimming commands (UP/DOWN) to the target address (1. Destination address) occurs.

On and Bright Out threshold

The motion sensor function can be adapted to the ambient light behaviour with the help of the On- and Off-Threshold.

ON Command threshold: The motion detection sequence can be started independent from the actual light level (default) or if the light level is above or below the OnCmd-threshold.

For a running motion sequence the presence detection – retriggering the sequence on motion - can either be set independent from the actual light level or only if the light level is below the **Bright out threshold**.

Bright out- Application example: Car Park lighting, that is set ON during the night (if measured light level < 70lux) but should not be kept ON during the day even though there might be constant detection of motion.

Power-On behaviour

It is possible to configure a start-up command to achieve a defined operating state after power on (return of the bus voltage). The start-up command can either be a DALI-command or a fast run of the motion detection sequence.

Multiple sensors in same group

It is possible that several sensors have the same effective range, e.g. if several sensors are used to cover a large detection area. In the DALI Cockpit software (tab: "Synchronisation") the sensor addresses used for motion detection and sensor addresses used for light detection can be specified. Backward compatibility for older generation CS is made possible by the option "Backward compatibility with eDALI CS". Definition of the same effective range (target address 1) automatically synchronizes older generation sensors. The parameters of the sensors should be coordinated, especially the hold on times.

Factory Setting

For simple applications the factory settings are sufficient:

	DALI-2 CS Art. Nr.: 86458670	DALI-2 CS Integration Art. Nr.: 86458670-INT
DALI-2 Settings	Application Controller – Master Mode	Instance Mode – Slave Mode
Operating Mode	Motion detection without constant light control, an external <i>ON command</i> deactivates motion detection until the next external <i>OFF command</i>	NA
Effective range	Broadcast	NA
ON command (1)	Recall Max	NA
Hold Time (2)	10min	NA
Absence value (3)	none	NA
Hold Time Absence (4)	0s	NA
OFF command (5)	Off	NA
OnCMD threshold	none	NA
Bright Out threshold	none	NA
Power Up behaviour	No action	NA
Constant light control (CLC)	inactive	NA
Front-LED (motion indication)	active	active
Instance 0 - motion event messages	inactive	active
Instance 1 – light intensity event messages	inactive	active

Configuration in DALI-Cockpit

The addressing and configuration of the DALI CS can be done easily with the help of the DALI Cockpit software tool and a suitable interface module (DALI USB, DALI 4Net, DALI SCI RS232). After an address has been assigned the parameters can be configured to fit the application.

The spatial allocation of each sensor can be done by visual localisation. Selection of the “localize” check box in the DALI cockpit will lead to flashing of the red LED of the currently selected sensor.

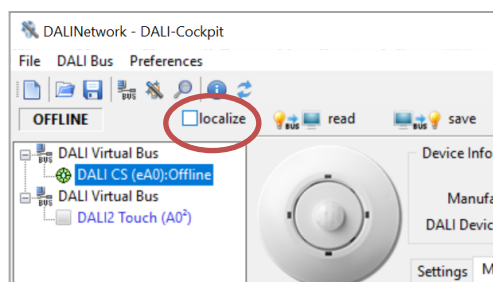

Configuration of the sensor is possible with the settings of the different tabs, explained in detailed on the following pages.

Tab: “General” – Sensor mode, Operating Mode:

Selection of the fundamental configuration is made on the “General” tab, see Figure. 5. The sensor can be set to Master or Slave Mode.

In *Master-Mode*, the DALI-2 CS takes over control according to the subsequently selected operating mode. The DALI-2 CS *Master* is an **application controller** and gives direct DALI control commands that are immediately executed by the DALI gears.

In *Slave-Mode*, the DALI-2 CS is in **instance mode** and does not send any control commands. Instead, the DALI-2 instances generate event messages that are interpreted and processed by a DALI-2 CS in *Master* mode

or by higher-level DALI control unit (e.g. WAGO, Beckhoff, LUNATONE DALI-2 KNX gateway).

The screenshot shows the 'General' configuration tab for a DALI-2 CS device. It includes sections for 'Device Description', 'Behavior on DALI Reset Command', 'DALI-2 CS General Properties', 'DALI-2 Control Device Parameters', 'Membership in Groups for DALI-2 Controls', 'Sensor Mode', and 'Operating Mode'. Callout boxes provide detailed explanations for several key settings:

- Behavior on DALI Reset Command:** Adjustable behaviour on DALI Reset Command: Reset to factory default values, reset to DALI Standard values, or ignore the reset command.
- Switch on red LED when moving:** If movement is detected, the red LED on the sensor lights up.
- synchronization with DALI CS (eDALI):** Backwards compatibility to enable synchronization of motion detection with 1st generation CS.
- Membership in Groups for DALI-2 Controls:** Control devices can be assigned to Instance groups. The assignment applies to the light sensor and the motion detector instance simultaneously.
- Sensor Mode:**
 - Master-Mode: Application Controller enabled:** In **master mode** – as an **application controller**, the device takes over the control depending on the operating mode.
 - Slave-Mode: Event Messages enabled:** In **slave mode - instance mode**, the DALI-2 CS sends event messages with the measured sensor values, these can be evaluated by a DALI-2 CS master.
- Operating Mode:** Operating mode: Selection between the four different operating modes of the application controller. - Description of the operating modes see section "Operating modes" on page 9.

Figure. 5 Tab: "General" – sensor mode, operating mode

Tab: "Effective range" - effective range, external control and power-up behaviour

See Figure. 6. On this tab the effective range of is defined: which DALI-gears are controlled by the CS. In addition, external control addresses can be defined, which the CS also monitors. The behaviour of the CS in case of other

control units sending commands to these addresses can be defined. This way, manual control of lights via a switch can be realised, without interference of the motion detection or constant light control.

Figure. 6 Tab: "Effective Range" – destination address and external control address

Tab: "Synchronization" – sensor input and Slaves

See Figure. 7. To include other sensor measurements into the evaluation, additional DALI-2 CS can be selected as sensor inputs. The selected DALI-2 CS are automatically set to slave mode by the currently configured

DALI-2 CS (Master). Depending on the operating mode, different sensors input for each sensor-functionality can be defined:
 for "Motion detection":
 input for movement,
 input for light thresholds
 for "Motion detection with constant light control":

input for movement,
input for light thresholds,
input for constant light control

input for constant light control
for "Light control":
input for light thresholds.

for "Constant light control":

The screenshot shows the 'Synchronisation' tab with three sections for sensor input configuration:

- motion control – slave sensor input – selection by address:** Includes checkboxes for addresses 0-7. Address 0 is checked. Callout: "These DALI addresses define which other sensors are evaluated for **motion detection**. In order to detect movement in the room, movement detectors that support instance type 3 (303) are required. Up to 8 inputs can be defined. Nr. 0 is always the current CS itself (*Master*), all other input sensors are set to *Slave Mode*."
- constant light control – slave sensor input – selection by address:** Includes checkboxes for addresses 0-7. Address 0 is checked. Callout: "These DALI addresses define which of the sensors are evaluated for **constant light control**. In order to measure the brightness in the room, sensors are required that support instance type 4 (304). Up to 8 inputs can be defined. Nr. 0 is always the current CS itself (*Master*), all other input sensors are set to *Slave Mode*."
- light control – slave sensor input – selection by address:** Includes checkboxes for addresses 0-7. Address 0 is checked. Callout: "These DALI addresses define which other sensors are involved in **lighting control**. In order to measure the brightness in the room, sensors are required that support instance type 4 (304). Up to 8 inputs can be defined. Nr. 0 is always the current CS itself (*Master*), all other input sensors are set to *Slave Mode*."

Below these sections is a 'Sensor Evaluation Mode' dropdown menu set to 'Average'. Callout: "With the 'Sensor Evaluation Mode' it can be defined, whether a maximum, minimum or mean value of the various sensor values is used for the evaluation."

A 'Light sensor calibration...' button is highlighted. Below it is a 'Light sensor calibration' dialog box with the following fields:

- Current Light Level: 183 Lux
- light value offset: 0 Lux
- Buttons: Set, Cancel

Callout: "via the 'light sensor calibration', the currently measured light value can be read out and if necessary, adjusted with an offset value."

Figure. 7 Tab: "Synchronisation" – sensor inputs for measurement evaluation

Tab: “Motion Control“

See Figure. 8, in this tab, the times and light levels of the the motion detection sequence, that is triggered by movement, can be

defined. As well as the light thresholds to activate the motion detection depending on the lighting conditions. (operating mode description see page 9 and page 10)

Display of the currently measured light values of the defined sensor input as a reference.

Settings for the motion detection sequence - (light levels, hold times (2) / (4)) with settings for constant light control depending on the operating mode.

The following commands can be selected as **ON commands (1)**: DAP, RECALL MAX, RECALL MIN, GOTO LAST ACTIVE LEVEL, GOTO SCENE X;

The following commands are available as commands for the **2nd light value (3)**: no action, DAP, RECALL MAX, RECALL MIN, GOTO SCENE X;

The following commands are available for the **OFF command (5)**: DAP, OFF, GOTO SCENE X;

Switch-on and switch-off threshold : adjustable whether the motion detection is active above or below a threshold value
Adjustable: threshold and width of the hysteresis (value range: 0... 1020Lux (step width 4 Lux)).

Bright Out threshold: if this threshold is exceeded the motion sequence is no longer retriggered on movement .
Application example: Parking lot - Ending the motion detection at dawn (crossing of threshold), although the sensor is currently in the movement state and movement is detected.

Via scenes, alternative behaviour to the main configuration can be activated (e.g. alternative destination address). Different options are available depending on the operating mode - see page 17

Figure. 8 Tab: „motion detection control“

Motion Control - Behaviour with external commands

The operating behaviour can be influenced by external commands (e.g. from a DALI-switch).

In the Cockpit tab "Effective range", the behaviour of the sensor on ON- / OFF- and dimming commands, sent to the 4 configurable "external control addresses", can be defined.

Additionally, the operating behaviour of the sensor can be changed with scene commands, via the tab "Motion detection" -section: Variable Operating Behaviour.

The following settings are available:

Operating mode 1 – motion detection

An external ON command
No influence: the ON command is ignored by the CS. The CS continues to carry out the control as configured
External control: motion control is deactivated (The CS does not send any DALI commands), until manually reactivated by an external OFF command.
Simulate movement: start the Motion Detection Sequence (Figure. 4, page 8)
An external OFF command
No influence: the OFF command is ignored by the CS. The CS continues to carry out the control as configured
Waiting for motion: change to State 5 and then to OFF state (state 7,Figure. 4), motion detection active - waiting for motion
Disable sensor control: change to state 5 and then to OFF state (state 7,Figure. 4), the motion detection is deactivated until reactivated by an ON command.

an external DIMMING command:
No influence: the DIMMING command is ignored by the CS. The CS continues to carry out the control as configured
External control: motion control is deactivated (The CS does not send any DALI commands), until manually reactivated by an external OFF command.
Change light level until end of sequence: the On command light level (State 2, Figure. 4) is changed by dimming. The new light level is retained for the current movement detection sequence

Variable Operating Behaviour - An external SCENE command
No action: the SCENE command is ignored by the CS.
Reset to Default: The CS is set to the basic configuration, all previously forced changes to the operating behaviour are terminated.
Alternative destinations: An alternative destination address (user defined) is used instead of the configured standard destination.
Alternative ON Command Light Level DAP: Instead of the currently configured DALI command, a user defined DAP value is used in state 2 (Motion Detection Sequence Figure. 4).
Alternative ON Command SCENE: Instead of the currently configured DALI command, a user defined Scene is used in state 2 (Motion Detection Sequence Figure. 4).
Waiting for motion: go to State 5 and then to OFF state (state 7,Figure. 4), motion detection active - waiting for motion

Operating Mode 2 – motion detection with constant light control

An external ON command
No Influence: the ON command is ignored by the CS. The CS continues to carry out the control as configured

<p>External control: Constant light control and motion control are deactivated (The CS does not send any DALI commands). until they are reactivated by an external OFF command.</p>	<p>Change constant light control reference light level until end of sequence: the reference light level for constant light control is changed by dimming. If no dimming process is detected for 2 seconds, the current light value is adopted as the new setpoint for the constant light control. The new setpoint is only retained for the current movement detection sequence (as long as movement is detected).</p>
<p>Simulate movement: start the Motion Detection Sequence (Figure. 4, page 8)</p>	<p>Change constant light control reference light level: the reference light level for constant light control is changed by dimming. If no dimming process is detected for 2 seconds, the current light value is adopted as the new setpoint for the constant light control.</p>
<p>Simulate movement without constant light control: Starts the motion detection sequence (State 1, Figure. 4) and deactivates the constant light control. The sent ON command is executed instead of constant light control. The constant light control is temporarily deactivated until the OFF-state (state 7,Figure. 4) is reached.</p>	
<p>Constant Light Control: The motion detection is deactivated and constant light control is permanently active until it is cancelled by an OFF command. (Standard behaviour is thereby reactivated)</p>	
<p>An external OFF command</p>	<p>Variable Operating Behaviour - An external SCENE command</p>
<p>No Influence: the OFF command is ignored by the CS. The CS continues to carry out the control as configured</p>	<p>No action: the SCENE command is ignored by the CS</p>
<p>Waiting for motion: Got to OFF state - go to State 5 and then to OFF state (state 7,Figure. 4), motion detection active - waiting for motion</p>	<p>Reset to defaults: The CS is set to the basic configuration, all previously forced changes to the operating behaviour are terminated.</p>
<p>Disable sensor control: change to state 5 and then to OFF state (state 7,Figure. 4) , the motion detection is deactivated until reactivated by an ON command. Enables: <i>„Off Only “: if the CS should only send an off command after a manual on (simulate movement) after the hold time has expired</i></p>	<p>Alternative destinations: An alternative destination address (user defined) is used instead of the configured standard destination.</p>
<p>an external DIMMING command:</p>	<p>Alternative ON Command Light Level DAP: Instead of the currently configured DALI command, a user defined DAP value is used in state 2 (Motion Detection Sequence Figure. 4).</p>
<p>no influence: the DIMMING command is ignored by the CS. The CS continues to carry out the control as configured</p>	<p>Alternative ON Command SCENE: Instead of the currently configured DALI command, a user defined Scene is used in state 2 (Motion Detection Sequence Figure. 4, page 8).</p>
<p>External control: Constant light control and motion control are deactivated (the CS does not send any DALI commands) until they are reactivated by an OFF command.</p>	<p>Alternative constant light control reference light level: Instead of the current reference value an alternative user defined light level is used</p>
<p>Disable constant light control until end of sequence: constant light control is deactivated temporarily during Motion Detection Sequence (State 2). Automatic reactivation of constant light control after end of sequence</p>	<p>Disable Constant Light Control until end of sequence: constant light control is deactivated temporarily during Motion Detection Sequence (State 2). Automatic reactivation of constant light control once no more movement is detected.</p>

external control: Constant light control and motion control are deactivated. The CS does not send any DALI commands.

Waiting for motion: Got to OFF state - go to State 5 and then to OFF state (State 7, Figure. 4) motion detection active - waiting for motion

the Operating mode: "constant light control" was selected.

Operating mode: Light threshold control

See Figure. 9. If the Operating Mode: "Light-controlled" was selected the light sensor control functions as a threshold switch. A maximum of 4 thresholds can be defined. The defined DALI commands will be executed if the values are exceeded or fallen below of.

Tab: „Light Control“

Depending on the selected operating mode:

Operating mode: Constant light control

See Figure. 10. The tab "light control" contains the settings for constant light control (CLC) if

2 of the 4 available thresholds can also be used to send commands periodically. The commands are sent at a user-defined interval until the threshold condition is no longer met.

Display of the currently measured light values of the defined sensor input as a reference.

Predefine the two following two thresholds as hysteresis

Activate / deactivate the respective threshold

Setting the threshold value, the DALI command and whether this should be carried out when the threshold is exceeded or fallen below of. (Threshold (0... 1020 lux, step size 4lux), hysteresis: is the difference between the two set thresholds (0 ... 255 lux))

2 of the 4 threshold values can be sent with repetition, by choosing the time between repetitions greater than zero. (With 0h, 0min, 0sec no repetition is carried out). The respective commands are sent with the selected interval until the set condition is no longer met. *Application example: closing blinds when the incidence of light is too strong.*

Via scenes, alternative behaviour to the main configuration can be activated (e.g. alternative destination address). Different options are available depending on the operating mode - see page 21.

Figure. 9 Tab: „Light Control“ -Operating Mode: without constant light control

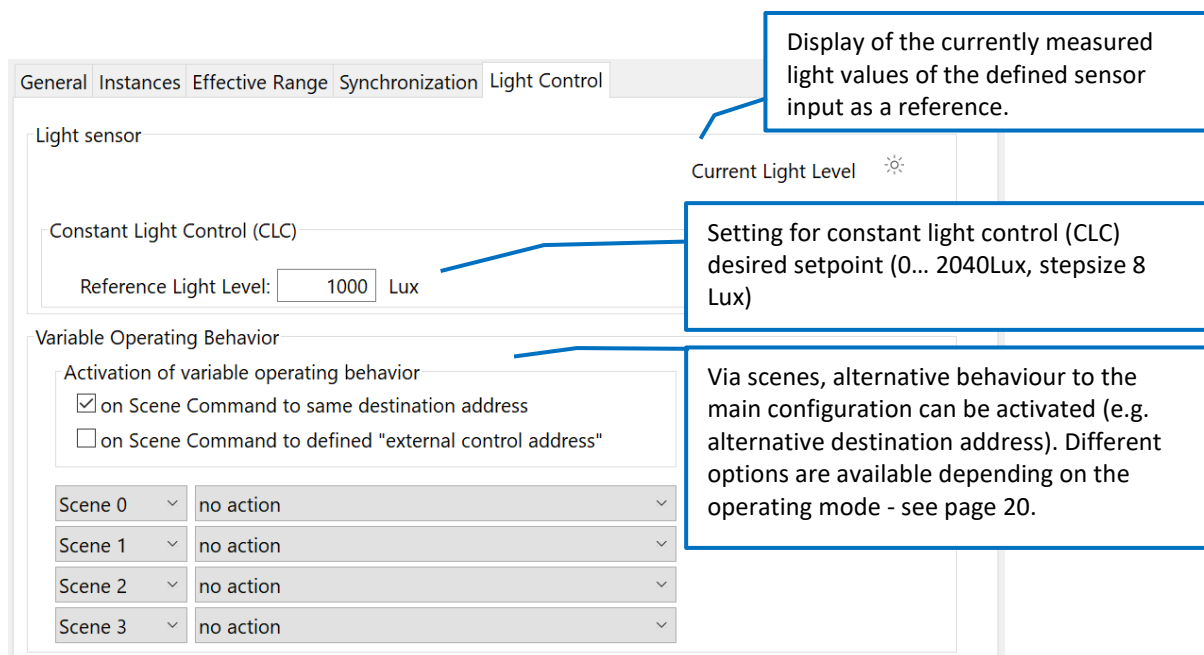

Figure. 10 Tab: „Light Control“ – Operating Mode : with constant light control

Light Control - Behaviour with external commands

The operating behaviour can be influenced by external commands (e.g. from a DALI-switch).

In the Cockpit tab "Effective range", the behaviour of the sensor on ON- / OFF- and dimming commands, sent to the 4 configurable "external control addresses", can be defined.

Additionally, the operating behaviour of the sensor can be changed with scene commands, via the tab "Motion detection" -section: Variable Operating Behaviour.

The following settings are available:

Operating Mode 3 – constant light control

An external ON command
No influence: the ON command is ignored by the CS. The CS continues to carry out the control as configured
External control: the constant light control is deactivated. (the CS does not send any DALI commands), until reactivated by an external OFF command.

Enable constant light control: The constant light control is activated.
An external OFF command
No influence: the OFF command is ignored by the CS. . The CS continues to carry out the control as configured
Disable constant light control: The constant light control is deactivated.
an external DIMMING command:
No influence: the DIMMING command is ignored by the CS. The CS continues to carry out the control as configured
Disable constant light control temporarily: constant light control is deactivated until the next OFF command.
Change constant light control reference light - temporary: the reference light level for constant light control is changed by dimming. If no further dimming process is detected for 2 seconds, the current light value is adopted as the new setpoint for the constant light control. The new setpoint is only retained until the next OFF command.

Change constant light control reference light level -general: the reference light level for constant light control is changed by dimming. If no dimming process is detected for 2 seconds, the current light value is adopted as the new setpoint for the constant light control.

Variable Operating Behaviour -
An external SCENE command

- No action:** the SCENE command is ignored by the CS
- Reset to Default:** The CS is set to the basic configuration, all previously forced changes to the operating behaviour are terminated.
- Alternative destinations:** An alternative destination address (user defined) is used instead of the configured standard destination.
- Alternative constant light control reference light level:** Instead of the current reference value an alternative user defined light level is used
- Enable constant light control:** The constant light control is activated.
- External Control:** The constant light control is deactivated (the CS does not send any DALI commands).

Operating Mode 4 – light threshold control

Variable Operating Behaviour -
An external SCENE command

- No action:** the SCENE command is ignored by the CS
- Reset to Defaults:** The CS is set to the basic configuration, all previously forced changes to the operating behaviour are terminated.
- Alternative Destinations:** An alternative destination address (user defined) is used instead of the configured standard destination.
- External control:** the light threshold control is deactivated (the CS does not send any DALI commands).

Instances

The DALI-2 CS and DALI-2 CS Integration support 2 instances standardized according to DALI: motion detector instance (303) for motion detection and light sensor instance (304) for light measurement.

In *Slave mode*, the DALI-2 CS is automatically in instance mode. The factory settings are designed for use in conjunction with a DALI-2 CS Master.

- Instance Nr. 0: Type motion detector
- Instance Nr. 1: Type light sensor

Instances – General

Each instance can be configured individually. Some settings have the same functionality for all sensor instances and are therefore described in this section. Instance specific settings are explained for each individual instances in the following respective sections.

enable/disable

If instances are not required, they can be deactivated. In this case, event messages are not sent, and the measured values are not updated. They can, however, still be queried via a “Query” command, and the DALI-2 configuration commands and queries are still supported.

Event Scheme

The event scheme determines which information is transferred with the event. This information is required, to enable recognition and / filtering of events on the bus. The following 5 options are available:

- Instance addressing:
instance type and instance number
- Device Addressing:
device address and instance type
- Device/Instance Addressing:
device address and instance number
- Device Group Addressing:

Device group and instance type

- Instance Group Addressing:
Instance group and instance type

Instance group

Up to three instance groups can be assigned for each instance. Only the "Primary Group" is used for the event.

Instance type

The instance type defines which DALI-2 standard is valid for this instance. (The different instance types are specified in the DALI-2 standard.)

Instance number

Each instance in a device has a unique instance number.

Device group

The device can be assigned to up to 32 device groups (0...31). The lowest device group is used for the event.

Device address

A device address (or short address) (0..63) can be assigned to each device. With this the device can be clearly addressed. (Identical short addresses should be avoided.)

Event priority

The event priority determines the order in which events are sent when they occur simultaneously on the bus. Priority 2 = highest and 5 = lowest.

Dead Time

The dead time can be set for each instance. It determines the time that must pass before an event can be sent again. This also applies if the event information (measured value) changes. If no dead time is required, it can be deactivated.

Report Time

If the event information does not change, the event is sent cyclically with the report time. The report time can be set for each instance. It determines the maximum time between a sent event and resending.

Hysteresis

Not every change in value leads to an event being generated. The hysteresis can be used to set which percentage change is necessary to trigger a new transmission. Attention, the hysteresis band is not arranged symmetrically. The following applies:

Increasing value

The condition for an event is only fulfilled if the next value falls below the previous value minus the hysteresis or if the next value is greater than the previous value.

Decreasing value

the condition for an event is only fulfilled if the next value exceeds the previous value plus the hysteresis or the next value is smaller than the previous value.

Hysteresis Min

Is the minimal hysteresis value that cannot be fallen below of.

Instance 0 – Motion

Is an instance standardized by DALI-2 (62386-303), for sensors that detect motion. All settings are implemented according to the standard. The instance is DALI-2 certified.

The sensor switches between the following states:

- People in the room and movement (0xFF)
- People in the room and no movement (0xAA)
- Empty room (0x00)

If the sensor detects movement, it immediately changes to the state: "people in the room and movement". This state is exited

after 1 second at the earliest if no further movement is detected. In this case it changes to the state "People in the room and no movement". After the hold time has expired it changes to the state "Empty room"- Vacant.

Hold Time: Is the time that must pass before the state "people in the room and no movement" is changed to the state "empty room". If movement is detected during this time the state is changed back to: "People in the room and movement". (min. 1 second)

Query Input Value: The current sensor state can be queried using this DALI command. The following values are possible: 0x00, 0xAA,0xFF (see paragraph above for the possible states)

Event: the sensor status is transmitted by events. The following event information is available:

- Bit0 = 0: No Movement
- Bit0 = 1: Movement
- Bit2/Bit1 = 00: Vacant
- Bit2/Bit1 = 10: Still Vacant
- Bit2/Bit1 = 01: Occupied
- Bit2/Bit1 = 11: Still Occupied
- Bit3 = 1: Movement Sensor
- Bit5..Bit9 = 0: unused

More details can be found in the standard 62386-303.

Event filter: The event filter defines for which status change an event is generated.

Filter arrangement:

- Bit0: Occupied Event active
- Bit1: Vacant Event active
- Bit2: Still Vacant/Occupied Event active
- Bit3: Movement Event active
- Bit4: No Movement Event active
- Bit5..Bit7: unused

Report Time: can only be set if the event filter "Repeat" is activated and the events: "Still Vacant" and "Still Occupied" are enabled. The

time between sending a "Still-Event" again is determined by the Report Time.

Instance 1 – Light intensity

is an instance standardized by DALI-2 (62386-304). All settings are implemented according to the standard. The instance is DALI-2 certified.

The current light value (lux) is measured by the sensor and can either be queried using a "Query" command or can be automatically provided by the sensor using an event.

The measuring range is 0Lux ... 2046Lux. The resolution differs between queries and generated events. A query supports a resolution of 1Lux (11Bit) and an event a resolution of 2Lux (10Bit).

Hysteresis: For information on the hysteresis see section Instances -General: *Hysteresis* page 22.

Hysteresis Min: set in lux. For general information on the hysteresis min see section Instances – General: *Hysteresis Min* page 22

Event Filter: The light instance generates only one event with 10-bit resolution (0... 2047 lux, step size 2lux). If the filter is deactivated, no events will be sent.

Cockpit - Instances

The settings for the instances can be made in the Cockpit – tab “Instances”.

Example for settings of instance 0 – motion see Figure. 11. Example for settings of instance 1 – light intensity see Figure. 12

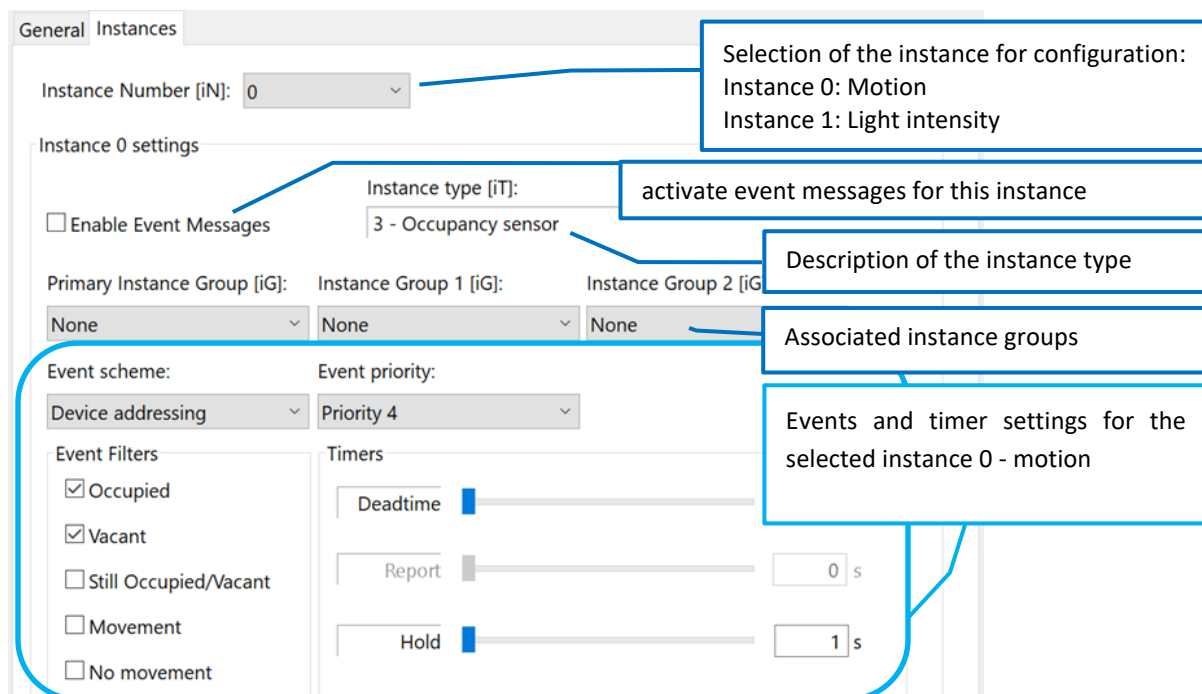

Figure. 11 tab: „Instances“ – motion detector instance

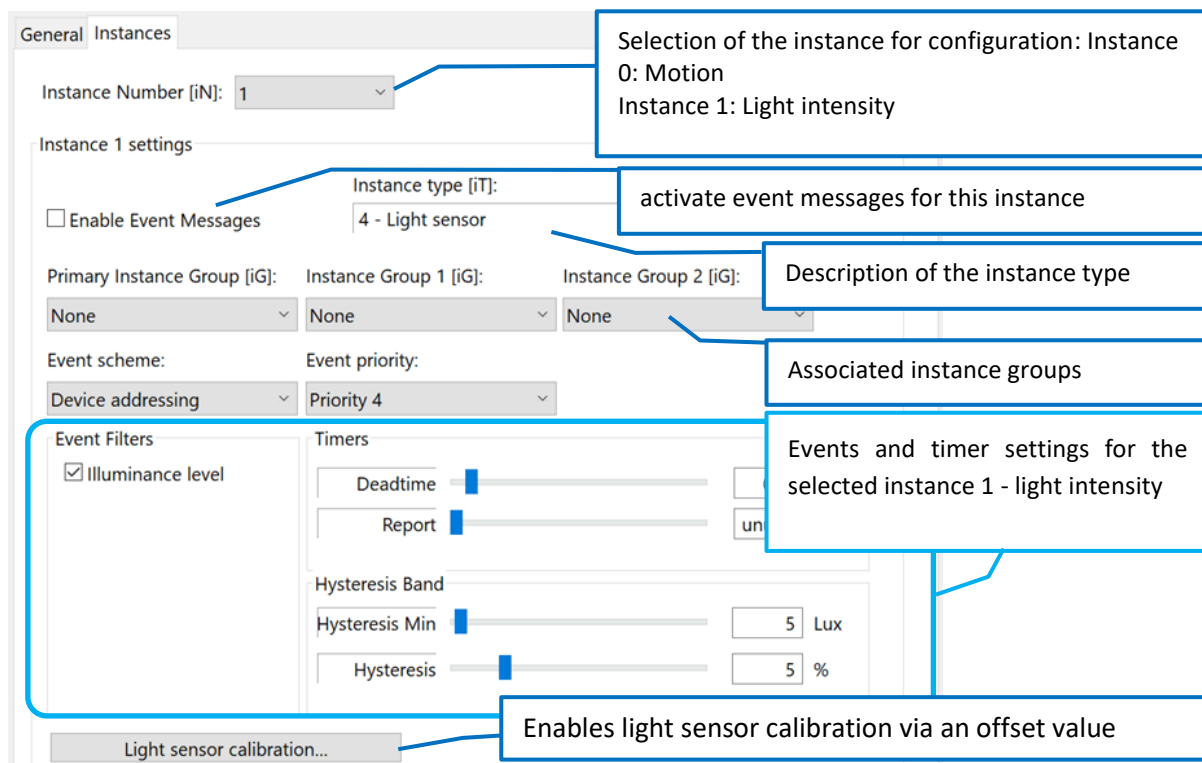

Figure. 12 tab: “instances“ – light sensor instance

Purchase Order Information



ARTICLE BASIS	DALI-2 FUNCTION	SENSOR, detection range & mounting height	COLOUR	INSTALLATION TYPE
86458670				
	<ul style="list-style-type: none"> Application Controller and DALI-2 instances INT = only DALI-2 instances 	<ul style="list-style-type: none"> standard, 12m & 8m 15 = especially for high rooms, 15m & 12m O = Detection of minor movements, 2.3m / 3m & 3m 	<ul style="list-style-type: none"> RAL 9010 W16 = RAL 9016 B = black 	<ul style="list-style-type: none"> standard ZD = suspended ceiling type with clasp AP = surface mounting type

Motion Sensor Lens type

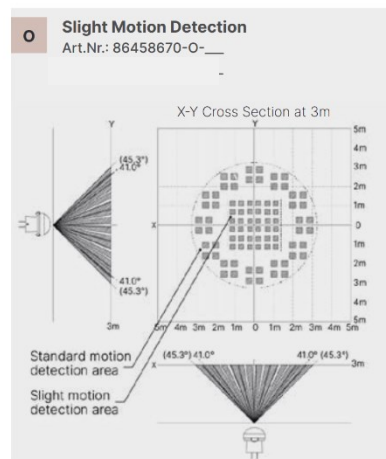
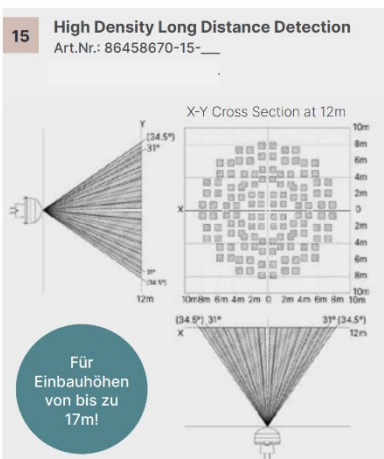
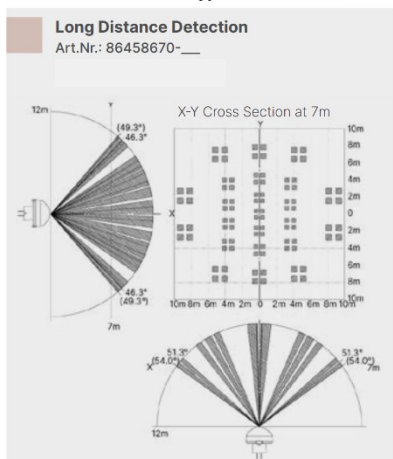

Installation type

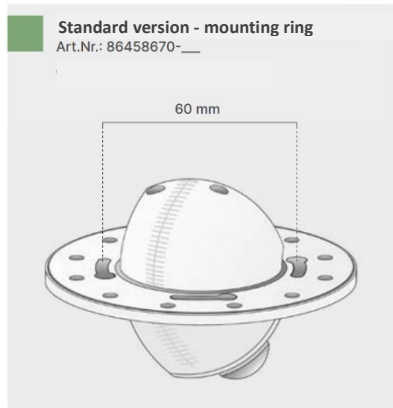

Standard Version

Art.Nr. 86458670: DALI-2 CS, sensor module (motion/ light), **Application Controller and Instance mode**, pure white (RAL9010), back box installation

Art.Nr. 86458670-AP pure white (RAL9010), surface mounting

Art.Nr. 86458670-ZD pure white (RAL9010), suspended ceiling (spring)

Art.Nr. 86458670-W16 traffic white (RAL9016), back box installation

Art.Nr. 86458670-W16-AP traffic white (RAL9016), surface mounting

Art.Nr. 86458670-W16-ZD traffic white (RAL9016), suspended ceiling (spring)

Art.Nr. 86458670-B black, back box installation

Art.Nr. 86458670-B-AP black, surface mounting

Art.Nr. 86458670-B-ZD: black, suspended ceiling (spring)

Art.Nr. 86458670-INT: DALI-2 CS Integration, sensor module (motion/ light), **Instance mode for Integration**, pure white (RAL9010), back box installation

Art.Nr. 86458670-INT-AP pure white (RAL9010), surface mounting

Art.Nr. 86458670-INT-ZD pure white (RAL9010), suspended ceiling (spring)

Art.Nr. 86458670-INT-W16 traffic white (RAL9016), back box installation

Art.Nr. 86458670-INT-W16-AP traffic white (RAL9016), surface mounting

Art.Nr. 86458670-INT-W16-ZD: traffic white (RAL9016), suspended ceiling (spring)

Art.Nr. 86458670-INT-B black, back box installation

Art.Nr. 86458670-INT-B-AP black, surface mounting

Art.Nr. 86458670-INT-B-ZD: black, suspended ceiling (spring)

Hall Version – for halls / high ceilings: presence detection range 15m

Art.Nr. 86458670-15: DALI-2 CS, sensor module (motion/ light), presence detection range 15m, **Application Controller and Instance mode**, pure white (RAL9010), back box installation

Art.Nr. 86458670-15-AP pure white (RAL9010), surface mounting

Art.Nr. 86458670-15-ZD pure white (RAL9010), suspended ceiling (spring)

Art.Nr. 86458670-15-W16 traffic white (RAL9016), back box installation

Art.Nr. 86458670-15-W16-AP traffic white (RAL9016), surface mounting

Art.Nr. 86458670-15-W16-ZD: traffic white (RAL9016), suspended ceiling (spring)

Art.Nr. 86458670-15-B black, back box installation

Art.Nr. 86458670-15-B-AP black, surface mounting

Art.Nr. 86458670-15-B-ZD: black, suspended ceiling (spring)

Art.Nr. 86458670-INT-15: DALI-2 CS Integration, sensor module (motion/ light), presence detection range 15m, **Instance mode for Integration**, pure white (RAL9010), back box installation

Art.Nr. 86458670-INT-15-AP pure white (RAL9010), surface mounting

Art.Nr. 86458670-INT-15-ZD pure white (RAL9010), suspended ceiling (spring)

Art.Nr. 86458670-INT-15-W16 traffic white (RAL9016), back box installation

Art.Nr. 86458670-INT-15-W16-AP traffic white (RAL9016), surface mounting

Art.Nr. 86458670-INT-15-W16-ZD: traffic white (RAL9016), suspended ceiling (spring)

Art.Nr. 86458670-INT-15-B black, back box installation

Art.Nr. 86458670-INT-15-B-AP black, surface mounting

Art.Nr. 86458670-INT-15-B-ZD: black, suspended ceiling (spring)

Office Version - for office applications: detection of small movement / seated people

Art.Nr. 86458670-O: DALI-2 CS, sensor module (motion/ light), for office applications (detection of arm movement of seated persons), **Application Controller and Instance mode**, pure white (RAL9010), back box installation

Art.Nr. 86458670-O-AP pure white (RAL9010), surface mounting

Art.Nr. 86458670-O-ZD pure white (RAL9010), suspended ceiling (spring)

Art.Nr. 86458670-O-W16 traffic white (RAL9016), back box installation

Art.Nr. 86458670-O-W16-AP traffic white (RAL9016), surface mounting

Art.Nr. 86458670-O-W16-ZD traffic white (RAL9016), suspended ceiling (spring)

Art.Nr. 86458670-O-B black, back box installation

Art.Nr. 86458670-O-B-AP black, surface mounting

Art.Nr. 86458670-O-B-ZD black, suspended ceiling (spring)

Art.Nr. 86458670-INT-O: DALI-2 CS Integration, sensor module (motion/ light), (detection of arm movement of seated persons), **Instance mode for Integration**, pure white (RAL9010), back box installation

Art.Nr. 86458670-INT-O-AP pure white (RAL9010), surface mounting

Art.Nr. 86458670-INT-O-ZD pure white (RAL9010), suspended ceiling (spring)

Art.Nr. 86458670-INT-O-W16 traffic white (RAL9016), back box installation

Art.Nr. 86458670-INT-O-W16-AP traffic white (RAL9016), surface mounting

Art.Nr. 86458670-INT-O-W16-ZD traffic white (RAL9016), suspended ceiling (spring)

Art.Nr. 86458670-INT-O-B black, back box installation

Art.Nr. 86458670-INT-O-B-AP black, surface mounting

Art.Nr. 86458670-INT-O-B-ZD black, suspended ceiling (spring)

Additional Information and Equipment

DALI-Cockpit – free configuration tool from Lunatone for DALI systems

<https://www.lunatone.com/en/product/dali-cockpit/>

Lunatone DALI products

<http://www.lunatone.at/en/>

Lunatone datasheets and manuals

<http://lunatone.at/en/downloads/>

Contact

Technical Support: support@lunatone.com

Requests: sales@lunatone.com

www.lunatone.com



Disclaimer

Subject to change. Information provided without guarantee.
The datasheet refers to the current delivery.

The function in installations with other devices must be tested for compatibility in advance.