

## Digital **DALI** electronic ballasts for T5 fluorescent lamps

freedom in lighting

- Digital DALI control
- Switch-Control \*
- Stand-by consumption 0.3 W
- Dimming range 1-100 % \*\*
- Only 21 mm high
- Microprocessor controlled
- Standard & sidemount possibilities
- User friendly, quick release connectors

**14-80 W 220-240 V, 50-60 Hz**



### A1 BAT



Lamp type	Wattage	No. of lamps	Ballast	EEI	Dimensions	Connection	Weight	Circuit power	Mains current	Lamp power
						(p. 14)	(g)	(W)	(A)	(W)
<b>T5</b>	14	1	EL1x14-35iDim	A1 BAT	1	1	250	17	0.08-0.07	13.7
	14	2	EL2x14-35iDim	A1 BAT	2	2	330	32.5	0.15-0.14	13.7
	14	3	EL3x14iDim	A1 BAT	2	3	310	47.5	0.22-0.20	13.7
	14	4	EL4x14iDim	A1 BAT	2	4	330	62	0.29-0.27	13.7
	21	1	EL1x14-35iDim	A1 BAT	1	1	250	23.5	0.11-0.10	20.7
	21	2	EL2x14-35iDim	A1 BAT	2	2	330	46	0.22-0.20	20.7
	24	1	EL1x24iDim	A1 BAT	1	1	250	25.5	0.12-0.10	22.5
	24	2	EL2x24iDim	A1 BAT	2	2	330	50.5	0.23-0.21	22.5
	28	1	EL1x14-35iDim	A1 BAT	1	1	250	32	0.15-0.14	27.8
	28	2	EL2x14-35iDim	A1 BAT	2	2	330	62	0.28-0.26	27.8
	35	1	EL1x14-35iDim	A1 BAT	1	1	250	39	0.18-0.17	34.7
	35	2	EL2x14-35iDim	A1 BAT	2	2	330	73.5	0.36-0.30	34.7
	39	1	EL1x39iDim	A1 BAT	1	1	250	42.5	0.20-0.18	38
	39	2	EL2x39iDim	A1 BAT	2	2	330	82.5	0.38-0.35	38
	49	1	EL1x49iDim	A1 BAT	1	1	250	55	0.25-0.23	49.3
	49	2	EL2x49iDim	A1 BAT	2	2	330	107.5	0.49-0.45	49.3
	54	1	EL1x54iDim	A1 BAT	1	1	250	59	0.27-0.25	53.8
	54	2	EL2x54iDim	A1 BAT	2	2	330	117	0.53-0.49	53.8
	80	1	EL1x80iDim	A1 BAT	1	1	250	86	0.39-0.36	80
	80	2	EL2x80iDim *	A1 BAT	2	2	365	170	0.78-0.70	80

Note: See pages 14-17 for connection diagrams and additional characteristics.

\* No Switch-Control in EL2x80iDim

\*\* Dimming range 3-100 % for EL3x14iDim & EL4x14iDim

For information on compatibility with amalgam lamps, please contact your local Helvar representative.

Dimensions	1	2
Length 'a' (mm)	360	430
Width 'b' (mm)	30	30
Height 'c' (mm)	21	21
'd' (mm)	350	420

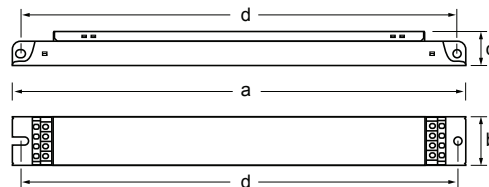

Delivery information					
Ballast	Unit package		Transportation package		
	Minimum delivery amount	Plastic binding strip	EUR pallet 1200 x 800 (pcs.)	Pallet weight (kg)	Pallet height (cm)
EL1 x iDim	10	●	980	300	40
EL2 x iDim	10	●	840	325	43
EL3 x iDim	10	●	840	325	43
EL4 x iDim	10	●	840	325	43

Right to use German patent DE19757295 of Tridonic Atco

## EL-iDim

NOTE: All wiring to the connectors marked with a red dot (hot wires) should be as short as possible.

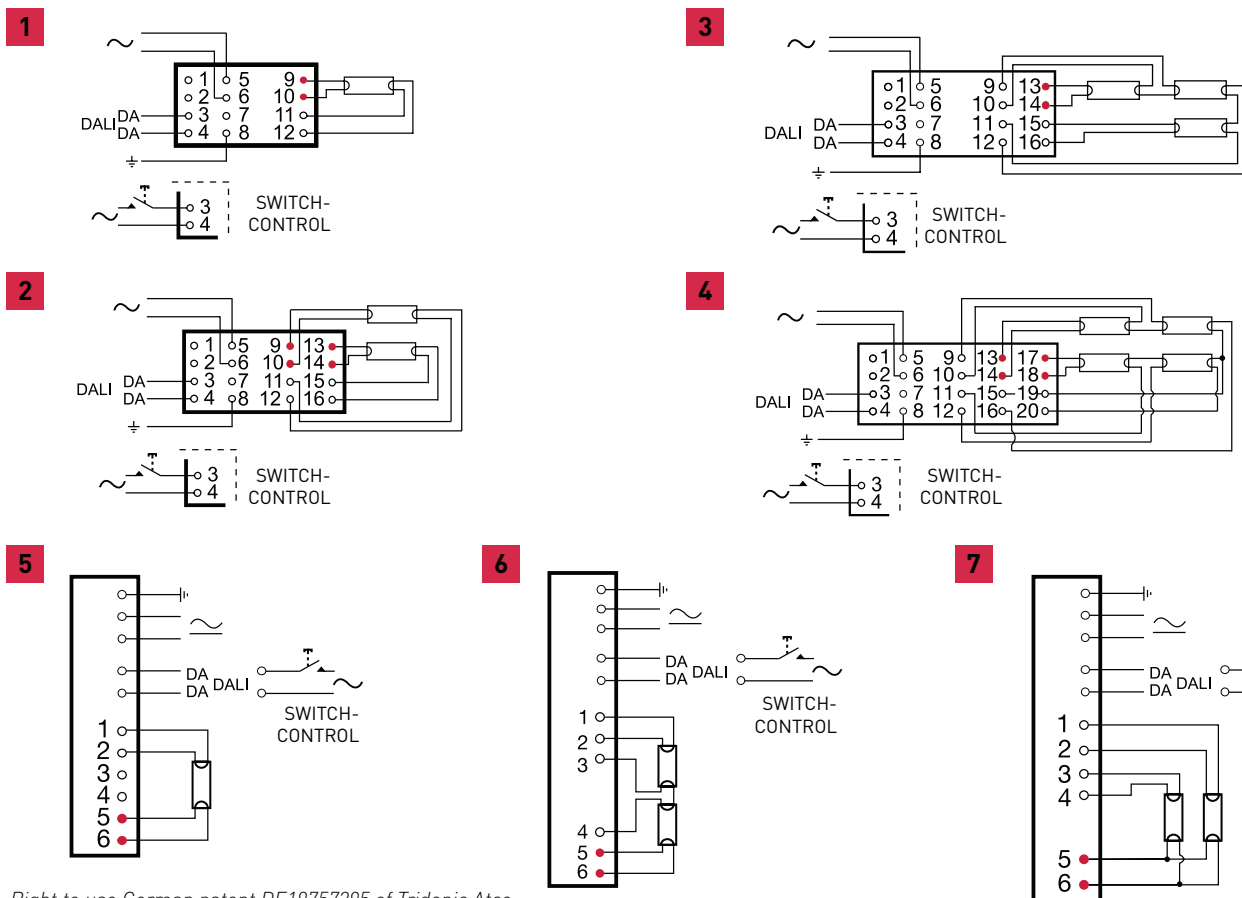

Right to use German patent DE19757295 of Tridonic Atco

1	EL1x ...iDim
2	EL2x ...iDim
3	EL3x ...iDim
4	EL4x ...iDim
5	EL1/2x...iDim-c
6	EL1/2x...iDim-c
7	EL2x...iDim-c

## EL-sc

NOTE: All wiring to the connectors marked with a red dot (hot wires) should be as short as possible.

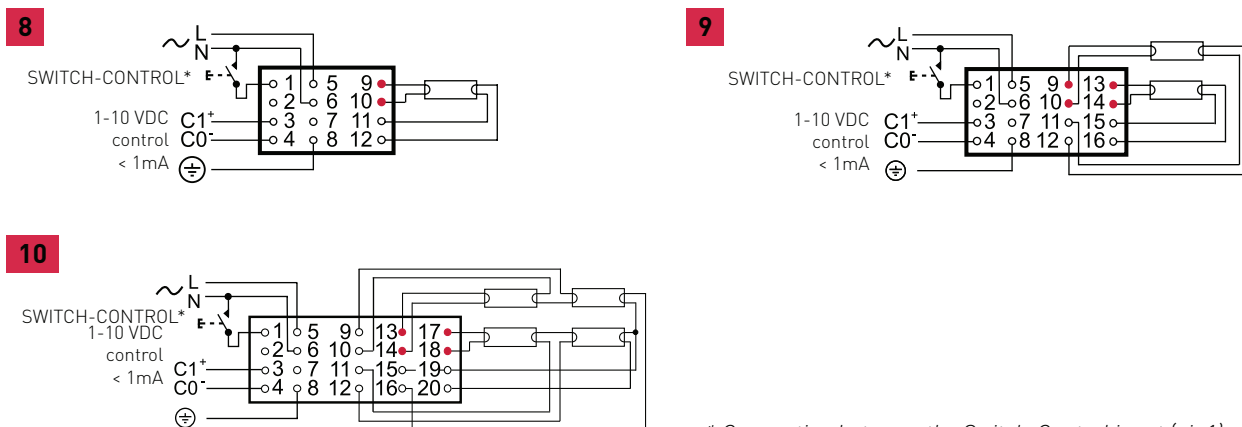

\* Connection between the Switch-Control input (pin 1) and N (or L).

1	EL1x ...sc
2	EL2x ...sc
3	EL4x ...sc

	EL-iDim	EL-iDim-c	EL-sc
Max.temperature at $t_c$ point	75 °C <sup>3)</sup>	75 °C	80 °C
Ambient temperature range	+10...+50 °C <sup>1) 5) 6)</sup>	+10...+50 °C <sup>5)</sup>	+10...+50 °C <sup>1)</sup>
Storage temperature range	-40...+80 °C	-40...+80 °C	-40...+80 °C
Maximum relative humidity	no condensation	no condensation	no condensation
Number of starts per lamp	> 50 000	> 50 000	> 50 000
AC Range	198-264 VAC	198-264 VAC	198-264 VAC
DC range (starting voltage >198VDC)	176-280 VDC	176-280 VDC	176-280 VDC
Over voltage duration	320 VAC, 1h	320 VAC, 1h	320 VAC, 1 h
EBLF (Emergency Ballast Lumen Factor)	N/A	> 0.5 <sup>7)</sup>	N/A
BLF (Ballast Lumen Factor), steady state	~1	~1	~1
Programmable light output for DC operation	yes	yes	N/A
Power factor (at maximum), typical	0.96	0.96	0.98
Earth leakage current	< 0.4 mA	< 0.4 mA	< 0.4 mA
Maximum working voltage (Uout)	400 V	400 V	400 V
Lifetime (90 % survival)	50 000 h, at $t_c$	50 000 h, at $t_c$	50 000 h, at 70 °C $t_c$
Max length of ballast to lamp wiring	1.5 m / 2 m (hot / cold) <sup>2) 4)</sup>	1 m / 1 m (hot / cold) <sup>4)</sup>	1.5 m/2 m (hot/cold) <sup>2)</sup>
Max length of DALI control wires	300 m <sup>9)</sup>	300 m <sup>9)</sup>	N/A
Ignition time, typical	1.0 s	1.0 s <sup>8)</sup>	<1.3 s
Type of starting	Preheat (warm start)	Preheat (warm start)	Preheat (warm start)

1) To ensure stable operation of TC-L lamps in ambient temperatures below 18 °C it is not recommended to dim the light level below 3 %

2) For TC-L lamps 1 m / 2 m (hot/cold lamp wires)

3) For EL 3x14iDim,  $t_c = 65$  °C

4) Minimise lamp wire length variations in order to avoid imbalance in light output.

5) When using EL3x14iDim, EL4x14iDim and EL1/2x18/24iDim-c ballasts in ambient temperatures below 15 °C it is not recommended to dim the light level below 10 % to ensure stable lamp operation.

6) For EL2x80iDim, it is not recommended to dim the light below 5 % in temperatures below 15 °C

7) EL2x26-42iDim-c; EBLF > 0,3

8) EL1/2x18/24iDim-c ignition time = 1.4 s

9) Maximum allowed voltage drop is 2 V in 250 m wire

## Standards

	EL-iDim	EL-iDim-c	EL-sc
General and safety requirements EN61347-2-3	●	●	●
Additional safety requirements for AC/DC supplied ballasts acc. to EN61347-2-3 Annex J	●	●	N/A
Performance requirements EN60929	●	●	●
Preheat starting	●	●	●
Lamp life acc. to EN60081 / EN60901 <sup>*)</sup>	●	●	●
Mains current harmonics, acc. to EN61000-3-2	●	●	●
Radio Frequency Interference, acc. to EN55015	●	●	●
Immunity standard, acc.to EN61547	●	●	●
Vibration test EN60068-2-64 test Fh	●	●	●
Bump test EN60068-2-29 test Eb	●	●	●
Thermal protection class EN61347, C5e	●	●	●
Tested and proven compatible with DALI V1 (IEC62386, 2009)	●	●	N/A

\* EN 60081 for T5 & T8 fluorescent lamps, EN 60901 for compact fluorescent lamps

Switch-Control provides ON/OFF switching and UP/DOWN dimming functionality from one or more simple switches.  
Switch-Control and DALI can not be connected to the iDim ballast at the same time.

**Suitable switch:**

- Automatic return type
- Mains rated

**Connection:**

- EL-iDim ballasts: To the DALI input
- Wire length: 25 m maximum, diagram A  
25 - 200 m, use a capacitor (1  $\mu$ F, 275 V), diagram B
- Ballasts per switch: 50 (observe above)
- Ensure all ballasts and associated switches are connected to the same mains phase

**Operation:**

- Switch off: Short push of the switch ( < 0.4 second)
- Switch on: Short push of the switch ( < 0.4 second)
- EL-iDim ballasts will switch on to the last set level
- Dimming: Long push of the switch ( > 0.5 second)
  - If lamps are off, the ballast dims up from minimum
  - If lamps are on, the ballast dims in the opposite direction to previously
  - The first dimming direction is dimming down

**Correction of out of sequence operation:**

- Switch the mains supply off and on, or...
- Long push (until all lamps are on), then a short push (all lamps off), then switch on

**Compatibility:**

Some ballasts manufacturers have functionality similar to Helvar Switch-Control. These methods are NOT COMPATIBLE with each other.

**Power On to last level function from Switch-Control**

Power On to last level function recalls the light level after mains break.  
Power On to last level operation sequence:

**Activation**

- Activation is started with the light switched ON using the following sequence.
  - 1 x long switch (20 - 25 s)
  - 3 x short switch (90 - 360 ms)
  - 1 x long switch (20 - 25 s)
 Between the switches, approximately 2 seconds of delay is allowed.

**Deactivation**

- Deactivation is started with the light switched OFF (standby) using the following sequence.
  - 1 x long switch (20 - 25 s)
  - 3 x short switch (90 - 360 ms)
  - 1 x long switch (20 - 25 s)
 Between the switches, approximately 2 seconds of delay is allowed.

**Connection**

- To the DALI input

**A) 0-25 m**

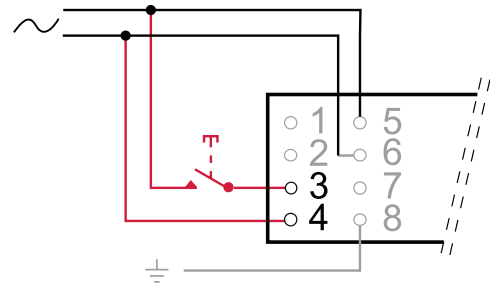

**B) 25-200 m**

