



Driver LCU 48V 150W DC-STR FO SR

Fixed output

Product description

- Independent fixed output DC-String constant voltage LED Driver
- Compatible with other DC-String components
- Max. output power 150 W
- Up to 93 % efficiency
- Nominal life-time up to 50,000 h
- For luminaires of protection class I and protection class II
- 5-year guarantee

Housing properties

- Casing: polycarbonate, white
- Type of protection IP20

Functions

- DC-String compatible
- Intelligent Temperature Guard (overtemperature protection)
- Short-circuit protection
- Overload protection



Standards, page 3



IP20 SELV 
RoHS

Driver LCU 48V 150W DC-STR FO SR

Fixed output

Technical data

Rated supply voltage	220 – 240 V
AC voltage range	198 – 264 V
DC voltage range	176 – 280 V
Mains frequency	0 / 50 / 60 Hz
Typ. current (at 230 V, 50 Hz, full load)	707 mA
Typ. current (220 V, 0 Hz, full load)	735 mA
Leakage current (at 230 V, 50 Hz, full load)	< 500 µA
Max. input power	162 W
Typ. efficiency (at 230 V / 50 Hz / full load)	93 %
λ (at 230 V, 50 Hz, full load)	0.99
Typ. input current in no-load operation	51 mA
Typ. input power in no-load operation	2.4 W
In-rush current (peak / duration)	671 A / 173.2 µs
THD (at 230 V, 50 Hz, full load)	< 5 %
Output voltage tolerance	-1 ... +7 %
Output LF current ripple (< 120 Hz)	± 1 %
Max. output voltage (no-load voltage)	51.3 V
Max. cable length secondary	See section 3.5
Mains surge capability (between L - N)	1 kV
Mains surge capability (between L/N - PE)	2 kV
Surge voltage at output side (against PE)	< 450 V
Ambient temperature t_a	-25 ... +50 °C
Max. casing temperature t_c	80 °C
Dimensions L x W x H	235 x 100 x 31 mm

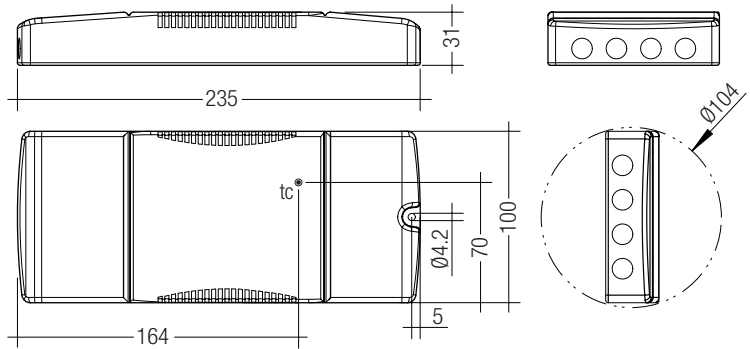

Ordering data

Type	Article number	Packaging carton	Packaging pallet	Weight per pc.
LCU 48V 150W DC-STR FO SR	28001045	10 pc(s).	300 pc(s).	0.365 kg

We recommended using following LMI LED Drivers together with this LCU DC power

supply:

Type	Article number	Packaging box	Packaging carton (contains 10 boxes)	Packaging pallet	Weight per pc.
LMI G2 48V 350-700mA 3-20V FO Slim	28000730	5 pc(s).	50 pc(s).	3,000 pc(s).	0.013 kg
LMI G2 48V 700-1050mA 3-20V FO Slim	28001582	5 pc(s).	50 pc(s).	3,000 pc(s).	0.016 kg
LMI 48V 350-700mA 20-42V FO Regular	28000728	5 pc(s).	50 pc(s).	3,000 pc(s).	0.016 kg
LMI 48V 350-700mA 20-42V FO Slim	28000947	5 pc(s).	50 pc(s).	3,000 pc(s).	0.016 kg

1. Standards

EN 55015
EN 61000-3-2
EN 61000-3-3
EN 61347-1
EN 61347-2-13
EN 62384
EN 61547

2. Thermal details and life-time

2.1 Expected life-time

Expected life-time					
Type	ta	40 °C	45 °C	50 °C	Load
LCU 48V 150W DC-STR FO SR	Life-time	70 °C	75 °C	80 °C	75 – 100 %
		90,000 h	70,000 h	50,000 h	75 – 100 %
		180,000 h	140,000 h	105,000 h	50 – 74 %
		>200,000 h	>200,000 h	170,000 h	25 – 49 %
		>200,000 h	>200,000 h	>200,000 h	0 – 24 %

The DC power supply is designed for a life-time stated above under reference conditions and with a failure probability of less than 10 %.

The relation of tc to ta temperature depends also on the luminaire design.

If the measured tc temperature is approx. 5 K below tc max., ta temperature should be checked and eventually critical components (e.g. ELCAP) measured. Detailed information on request.

3. Installation / wiring

3.1 Circuit diagram

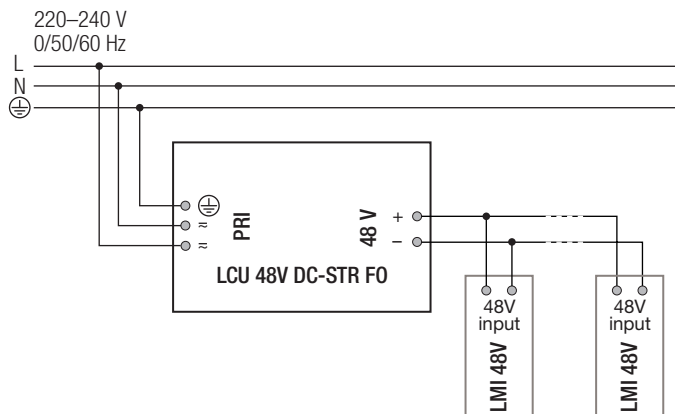

To the LCU 48V DC-STR FO there can be connected either LMI 48V fixed output version or LMI 48V dimmable version.

By using LCU 48V DC-STR FO together with LMI 48V dimmable version dimming is not possible.

3.2 Mains supply wiring

Stranded wire or solid wire up to 2.5 mm² may be used for wiring. Strip 10–11 mm of insulation from the cables to ensure perfect operation of the push terminals.

Use one wire for each terminal connector only.
Use each strain relief channel for one cable only.

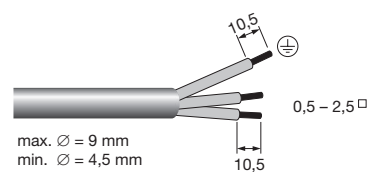

3.3 Output wiring (48 V bus)

The output wiring can be done with a cross section of 0.2 – 2.5 mm².

Strip 9 – 10 mm of insulation from the cables to ensure perfect operation of the push-wire terminals.

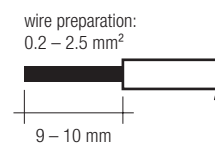

Use one wire for each terminal connector only.
Use each strain relief channel for one cable only.

3.4 Loose wiring

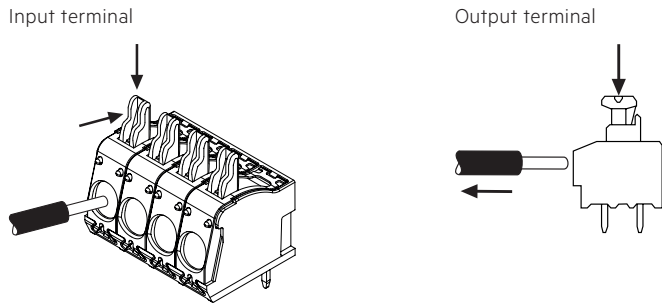

3.5 Wiring guidelines

- The 48 V cables should be run separately from the mains connections and mains cables to ensure good EMC conditions.
- The 48 V DC output wiring should be kept as short as possible to ensure good EMC. The max. secondary cable length is 30 m (60 m circuit) till beginning of a grounded metal track light. If track light is not grounded or made of plastic, cable length including track light is 30 m. Inside the track light cable length is limited by voltage drop that last LMI 48V in the track light is still supplied with minimum 46 V.
- Secondary switching is not permitted.
- To avoid the damage of the Driver, the wiring must be protected against short circuits to earth (sharp edged metal parts, metal cable clips, louver, etc.).

3.6 Hot plug-in

Hot plug-in during operation is supported for one DC/DC-LED Driver (LMI). It is only allowed to connect or disconnect one DC/DC-LED Driver (LMI) at the same moment onto the 48 V bus.

3.7 Function of the earth terminal ☺

The device has to be earthed to fulfill EMI requirements.

4. Electrical values

4.1 Efficiency vs. load

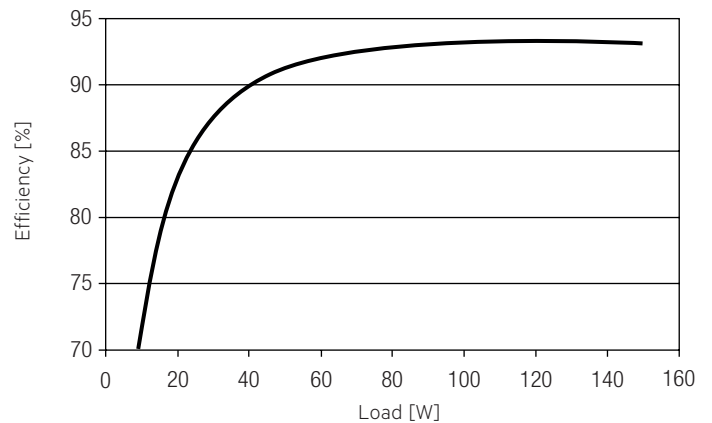

4.2 Power factor vs. Load

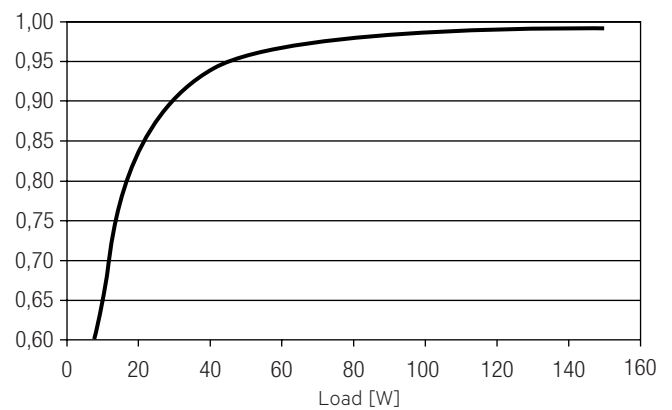

4.3 Input power vs. Load

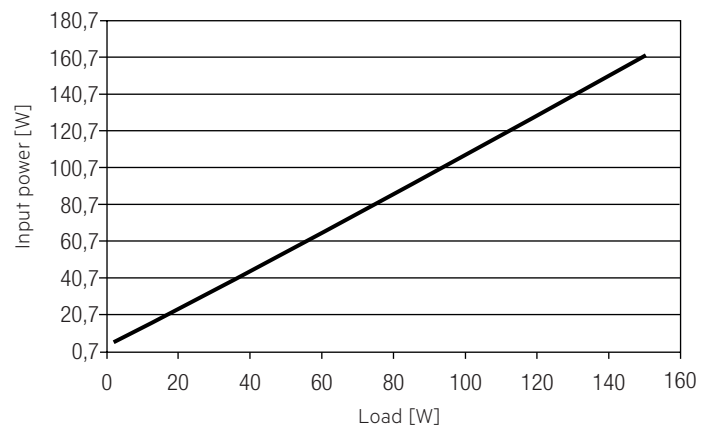

4.4 Input current vs. Load

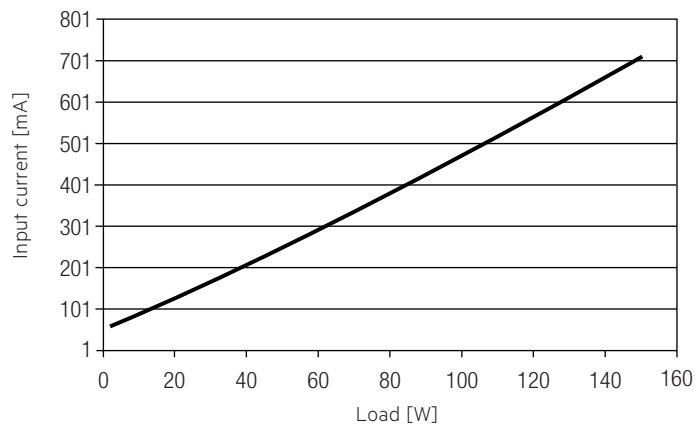

4.5 THD vs. Load

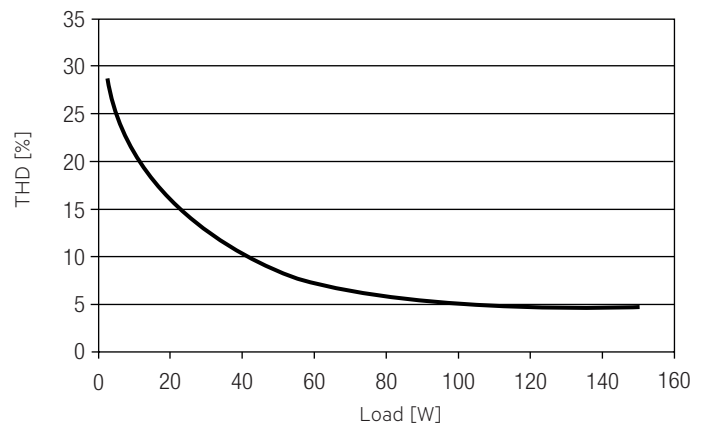

4.6 Maximum loading of automatic circuit breakers

Automatic circuit breaker type	C10	C13	C16	C20	B10	B13	B16	B20	Inrush current	
Installation Ø	1.5 mm ²	1.5 mm ²	2.5 mm ²	2.5 mm ²	1.5 mm ²	1.5 mm ²	2.5 mm ²	2.5 mm ²	I_{max}	time
LCU 48V 150W DC-STR FO SR	8	10	13	16	5	6	8	10	59 A	220 µs

Calculation uses typical values from ABB series S200 as a reference.
Actual values may differ due to used circuit breaker types and installation environment.

4.7 Harmonic distortion in the mains supply (at 230 V / 50 Hz and full load) in %

	THD	3.	5.	7.	9.	11.
LCU 48V 150W DC-STR FO SR	5	5	1	1	1	1

5. Functions

5.1 Short-circuit behaviour

In case of a short-circuit at the output the output is switched off. After restart of the DC power supply the output will be activated again. The restart can be done via mains reset.

5.2 No-load operation

The DC power supply will not be damaged in no-load operation.

5.3 Overload protection

If the output power range is exceeded by more than 10 % the DC power supply gives a blinking signal to the DC/DC-LED Driver.
The DC power supply will blink 5 times, after 30 s break, it checks again, if:

- there is no overload, then the device will go in normal operation.
- there is still overload, the device will blink again 5 times.

5.4 Overtemperature protection

The DC power supply will blink 3 times, after 30 s break, it checks again, if:

- there is no overtemperature, then the device will go in normal operation.
- there is still overtemperature, then the device will blink again 3 times.

5.5 DC operation

The DC power supply is designed for operation on DC voltage and pulsed DC voltage.
Behaviour in DC operation mode is the same as in AC operating mode.

6. Miscellaneous

6.1 Isolation and electric strength testing of luminaires

Electronic devices can be damaged by high voltage. This has to be considered during the routine testing of the luminaires in production.

According to IEC 60598-1 Annex Q (informative only!) or ENEC 303-Annex A, each luminaire should be submitted to an isolation test with 500 V_{DC} for 1 second. This test voltage should be connected between the interconnected phase and neutral terminals and the earth terminal.
The isolation resistance must be at least 2 MΩ.

As an alternative, IEC 60598-1 Annex Q describes a test of the electrical strength with 1500 V_{AC} (or 1.414 x 1500 V_{DC}). To avoid damage to the electronic devices this test must not be conducted.

6.2 Conditions of use and storage

Humidity: 5% up to max. 85%,
not condensed
(max. 56 days/year at 85%)

Storage temperature: -40 °C up to max. +80 °C

The devices have to be acclimatised to the specified temperature range (ta) before they can be operated.

6.3 Additional information

Additional technical information at www.tridonic.com → Technical Data

Guarantee conditions at www.tridonic.com → Services

Life-time declarations are informative and represent no warranty claim.
No warranty if device was opened.