



ZITARES CC

Constant current control gear, 1-channel, dimmable



ECG versions

Model	Order no.	Output currents	Output power
CCD135-18QS-01/220-240/1-10V	10078978	1 x 350 mA	max. 18 W
CCD170-35QS-01/220-240/1-10V	10078980	1 x 700 mA	max. 35 W
CCD135-18QS-01/220-240/DALI	10078979	1 x 350 mA	max. 18 W
CCD170-35QS-01/220-240/DALI	10078981	1 x 700 mA	max. 35 W

Performance characteristics

- Dimmable 1-channel ECG for constant current operation of LED modules
- SELV equiv. output voltage ≤ 60 VDC
- Very high efficiency of up to 90 % (100 % load)
- Soft start and low output current ripple
- For use in luminaires of protection class I
- ECG extensively protected against abnormal operating conditions at the output e.g. short-circuit, open circuit or overload
- Suitable for direct current operation and application in combination with central battery installations
- Overvoltage protection of the DALI and 1–10 V interfaces up to 264 VAC
- Push-Dim function of DALI interface: switching and dimming via push-button
- Settable recovery function: automatic switch-on after mains failure
- Dimming range: 1 ... 100 % luminous flux
- PWM dimming with 500 Hz for flicker-free light and prevention of stroboscopic effects
- Compact housing for maximum flexibility in luminaire design
- Identical dimensions for dimmable and non-dimmable versions
- Certified as thermally protected device
- Conformance with international regulations, regarding safety and operation, electromagnetic compatibility and immunity to interference
- Nominal service life: 50,000 h with failure rate ≤ 10 % and operation at $t_c = t_{c,max}$

Applications



Foyer



Hospitality



Shops

Markings





ZITARES CC

Constant current control gear, 1-channel, dimmable

General technical data

Mains voltage supply	
Rated voltage range	220 ... 240 V
Max. permanent voltage range (continuous)	198 ... 264 V
Rated frequency	0 / 50 ... 60 Hz
Battery operation	
Voltage range for continuous operation	198 ... 278 VDC
Lowest limiting value for temporary operation	176 VDC / 2 h
Mains overvoltage	
Overvoltage protection	350 VAC / 2 h
Automatic switch-off of the LEDs at	appr. 320 VAC
Protection against voltage peaks	
Voltage peaks L - N	1 kV
Voltage peaks L/N -PE	2 kV
Starting time	
Time to 100% luminous flux	< 0,5 s
Total harmonic distortion	
At 100% load operation	< 10 %
Output data	
Tolerance of output current	+/- 5 %
Max. ripple of output current	+/- 10 %
Max. wire length to LED module	2 m
Galvanic separation to mains input	yes, test voltage 3,75 kV
Protection functions output side	
Overload operation	yes; limitation of output voltage and reduction of output current
Underload protection	yes; pulsed operation
Short-circuit operation	yes; pulsed operation and reduced current amplitude
Open-circuit operation	yes; output voltage max. 60 VDC (SELV equiv.)
Hot plug-in	allowed; protection of LED module has to be ensured
Lifetime	
Operation at $t_c = t_{c,max}$	50.000 h; failure rate $\leq 10 \%$
Operation at $t_c = t_{c,max} - 10 \text{ K}$	100.000 h; failure rate $\leq 10 \%$
Dimming operation	
Dimming interfaces, depending on ECG model	DALI & Push-Dim or 1-10V
Control current for 1-10 V versions	$\leq 0.6 \text{ mA}$
Overvoltage protection of interface	264 VAC
Galvanic separation to output side	yes, test voltage 3.75 kV
Stand-by power losses	$\leq 0.3 \text{ W}$
Dimming range for luminous flux	1 ... 100 %
Dimming technology	500 Hz (PWM)
Max. number of ECG for Push-Dim control	25
Connection terminals	
Type	45°-terminal with key ¹⁾
Wire cross section	0,5 mm ² - 1,5 mm ²
Wire stripping length	7,5 mm - 8,5 mm
Thermal protected device	
Max. surface temperature acc. to EN 61347-1/C5e	+ 110° C
Degree of protection	
ECG-housing	IP 20

¹⁾ Terminals and ECG construction are designed for an automatic wiring with robots



ZITARES CC

Constant current control gear, 1-channel, dimmable

Temperatures (operation)

Model	Ambient (t_a)	Case (t_c)
CCD135-18QS...	- 25 °C ... + 55 °C	max. + 75 °C
CCD170-35QS...	- 25 °C ... + 50 °C	max. + 75 °C

Circuit breaker / Inrush current

Model	typ. $I_{peak} / \Delta t$	Number of ECG at one single-pole circuit breaker (CB)				
		LS-Type	10 A	16 A	20 A	25 A
CCD135-18QS...	36 A / 155 μ s	B	15	24	30	37
CCD170-35QS...		C	25	40	50	62

- Data for $U_{supply} = 230$ VAC, mains impedance = 1 Ω
- In case of multi-polar CB the maximum number is reduced by 20 %
- The max. number may differ depending on CB manufacturer. Please consider the specifications of the manufacturer.
- Basically, CB with C-characteristics are recommended to be used in lighting groups.

Typical current - time profile when switching on

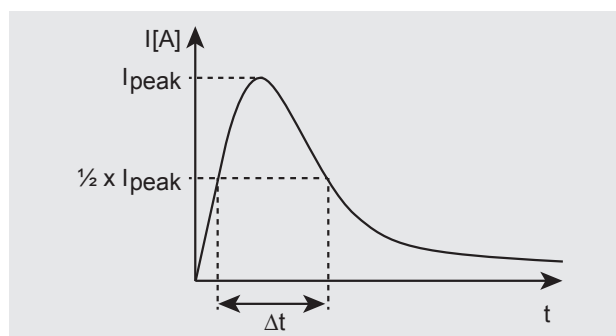

Operating data

Model	Input current ¹⁾ A	Input power ¹⁾ W	Power factor ¹⁾	ECG efficiency ¹⁾ %	Output currents mA	Output voltage / channel V	Total output power ²⁾ W
CCD135-18QS...	0,10	20	0,95	88	1 x 350	10 ... 50	3,5 ... 18
CCD170-35QS...	0,19	40	0,95	90	1 x 700	10 ... 50	7 ... 35

¹⁾ All specifications with 230 VAC nominal operation and 100 % load
²⁾ Power output in undimmed operation should not go below 10 % of the maximum permissible value

Wiring diagrams ECG

1 Connection of ECG input side for DALI control

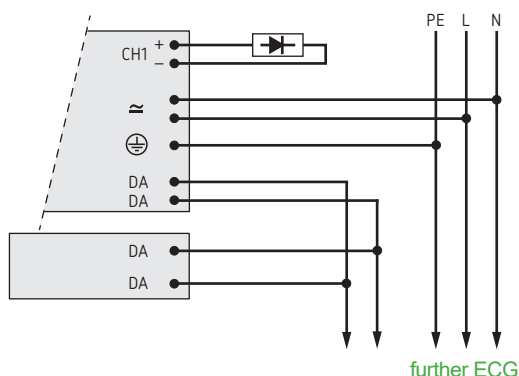

2 Connection of ECG input side for control via push-button

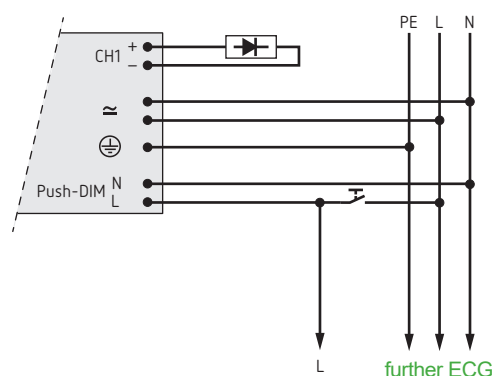



ZITARES CC

Constant current control gear, 1-channel, dimmable

Wiring diagrams ECG

3 Connection of ECG input side for 1 - 10V control

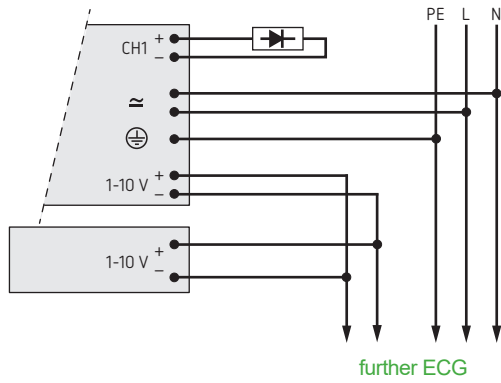

Efficiency and power factor

Efficiency vs. output load

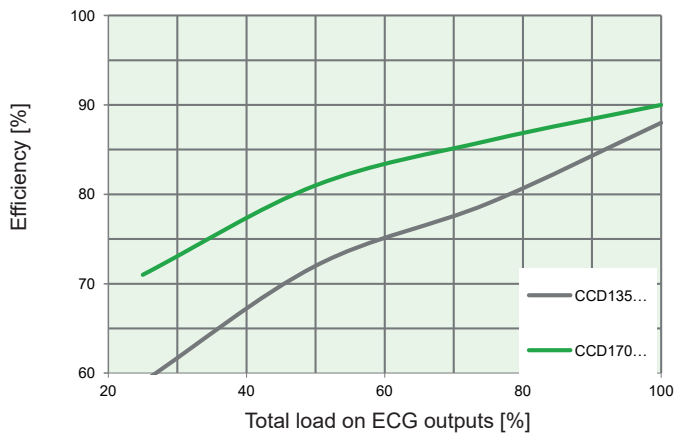

Power factor vs. output load

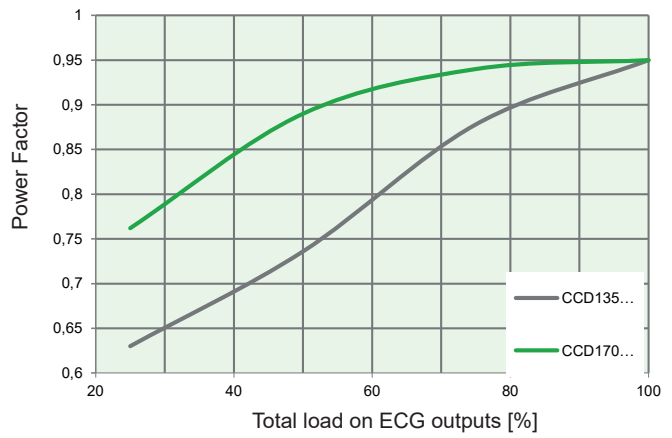



ZITARES CC

Constant current control gear, 1-channel, dimmable

○ Push-button operation/supplementary functions

Push-button operation

In addition to control via DALI control signals, the DALI interface can also be used for switching and dimming via a push-button.

Button press	Status: LEDs switched off, ECG in standby mode	Status: LEDs switched on
Short button press	Switching on of LEDs to the last dimming level (memory function)	Switching off of LEDs and saving of current dimming level; ECG in standby mode
Long button press	Switching on of LEDs to the last dimming level and then dimming up or dimming down	Dimming up or dimming down of LEDs; each release and re-pressing of the button reverses the dimming direction

Recovery function - behaviour after mains power interruption

The behaviour of the ECG after mains power interruption can be specified via the recovery function.

Recovery function activated: After return of mains voltage the ECG returns to the operating mode before power interruption. If the lighting system is switched on, the last set dimming level is called up.

Recovery function deactivated: (factory setting) After return of mains voltage the ECG switches the lighting to 100 % luminous flux.

Synchronisation of the ECG

If synchronising the ECG is needed in an application, this can be implemented via a push-button connected to the DALI interface. When the lighting system is switched on the push-button must be pressed and held for approximately 10 s until the complete system is increased to 100 % luminous flux. All ECGs are then synchronised after releasing the push-button.



ZITARES CC

Constant current control gear, 1-channel, dimmable

ECG dimensions

Model	X	X _M	Y	Y _M	Z
	mm	mm	mm	mm	mm
CCD135-18QS...	123	111	79	67	22
CCD170-35QS...	123	111	79	67	22

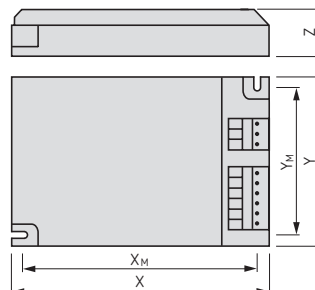

Logistic data

Model	Order no.	EAN	Weight ECG kg	ECG PU ¹⁾	Dimensions PU ¹⁾	Weight PU ¹⁾
				St.	mm	kg
CCD135-18QS-01/220-240/1-10V	10078978	4046189027182	0,175	30		
CCD170-35QS-01/220-240/1-10V	10078980	4046189027205	0,175	30		
CCD135-18QS-01/220-240/DALI	10078979	4046189027199	0,175	30		
CCD170-35QS-01/220-240/DALI	10078981	4046189027212	0,175	30		

¹⁾ Packaging unit

Conformance with regulations

EN 61347-1	General and safety requirements
EN 61347-2-13	Particular requirements for d.c. or a.c. supplied electronic control gear for LED modules
EN 62384	D.C. or A.C. supplied electronic control gear for LED modules - Performance requirements
EN 61547	Equipment for general lighting purposes - EMC immunity requirements
EN 55 015	Limits and methods of measurement of radio disturbance characteristics of electrical lighting and similar equipment
EN 62386-102	Digital addressable lighting interface - General requirements - Control gear
EN 62386-207	Digital addressable lighting interface. Particular requirements for control gear. LED modules (device type 6)
IEC 60 068-2-6	Environmental testing: Tests – Test Fc: Vibration (sinusoidal)
IEC 60 068-2-27	Environmental testing: Tests – Test Ea and guidance: Shock