



Driver LC 35W 700/800/1050mA flexC SR ADV

ADVANCED series

Product description

- Independent constant current LED Driver
- Adjustable output current between 700, 800 and 1,050 mA
- Max. output power 35 W
- Up to 87.5 % efficiency
- Nominal life-time up to 50,000 h
- For luminaires of protection class I and protection class II
- For luminaires with M and MM as per EN 60598, VDE 0710 and VDE 0711
- Temperature protection as per EN 61347-2-13 C5e
- 5-year guarantee



Housing properties

- Casing: polycarbonate, white
- Type of protection IP20

Interfaces

- Input terminals: 0° screw terminals
- Output terminals: 45° push terminals

Functions

- Overload protection
- Short-circuit protection
- No-load protection
- Overtemperature protection
- Burst protection voltage 1 kV
- Surge protection voltage 1 kV (L to N)
- Surge protection voltage 2 kV (L/N to earth)

Typical applications

- For spot light and downlight in retail and hospitality application
- For panel light and area light in office and education application



Standards, page 4

Wiring diagrams and installation examples, page 4

IP20 SELV 

RoHS 

Driver LC 35W 700/800/1050mA flexC SR ADV

ADVANCED series

Technical data

| | |
|--|-------------------------|
| Rated supply voltage | 220 – 240 V |
| AC voltage range | 198 – 264 V |
| Max. input current (at 230 V, 50 Hz, full load) | 0.19 A |
| Leakage current (at 230 V, 50 Hz, full load) | < 400 µA |
| Mains frequency | 50 / 60 Hz |
| Overvoltage protection | 320 V AC, 1 h |
| Max. input power | 42 W |
| Typ. power consumption (at 230 V, 50 Hz, full load) ^① | 42 W |
| Min. output power | 17.5 W |
| Max. output power | 35 W |
| Typ. efficiency (at 230 V / 50 Hz / full load) ^② | 87.5 % |
| λ (at 230 V, 50 Hz, full load) ^③ | 0.95 |
| Output current tolerance ^④ | ± 10 % |
| Max. output current peak ^⑤ | ≤ output current + 20 % |
| Max. output voltage | 60 V |
| THD (at 230 V, 50 Hz, full load) | < 10 % |
| Output LF current ripple (< 120 Hz) | ± 5 % |
| Time to light (at 230 V, 50 Hz, full load) | ≤ 0.5 s |
| Turn off time (at 230 V, 50 Hz, full load) | ≤ 0.5 s |
| Hold on time at power failure (output) | 0 s |
| Ambient temperature ta (at life-time 50,000 h) | 40 °C |
| Storage temperature ts | -40 ... +80 °C |
| Dimensions L x W x H | 159.4 x 82 x 34 mm |

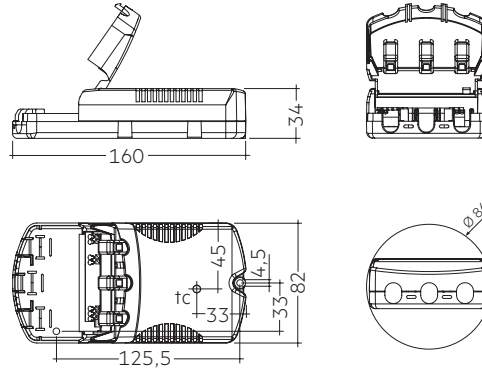

Ordering data

| Type | Article number | Packaging, carton | Packaging, low volume | Packaging, high volume | Weight per pc. |
|------------------------------------|----------------|-------------------|-----------------------|------------------------|----------------|
| LC 35W 700/800/1050mA flexC SR ADV | 28002494 | 20 pc(s). | 280 pc(s). | 1,120 pc(s). | 0.173 kg |

Specific technical data

| Type | Output current ^② | Min. forward voltage | Max. forward voltage | Max. output power | Typ. power consumption (at 230 V, 50 Hz, full load) | Typ. current consumption (at 230 V, 50 Hz, full load) | Efficiency (at 230 V, 50 Hz, full load) | Efficiency (at 230 V, 50 Hz, min. load) | Max. casing temperature tc | Ambient temperature ta max. | I-out select | Resistor ^④ |
|------------------------------------|-----------------------------|----------------------|----------------------|-------------------|---|---|---|---|----------------------------|-----------------------------|--------------|-----------------------|
| LC 35W 700/800/1050mA flexC SR ADV | 700 mA | 25.0 V | 50.0 V | 35 W | 41 W | 180 mA | 87.5 % | 83.5 % | 70 °C | -20 ... +50 °C | open | - |
| | 800 mA | 22.0 V | 44.0 V | 35 W | 41 W | 180 mA | 87.5 % | 82.5 % | 75 °C | -20 ... +50 °C | 0-1 | ADV Type A |
| | 1,050 mA | 16.5 V | 33.5 V | 35 W | 42 W | 190 mA | 86.0 % | 80.0 % | 75 °C | -20 ... +50 °C | 0-2 | ADV Type A |

^① Test result at 1,050 mA.

^② Output current is mean value.

^③ Test result at 25 °C.

^④ Type A is a short circuit plug (0 Ω).

^⑤ Test result at default output current.

ADV Plug for output current select

Product description

- Ready-for-use resistor to set output current value
- Compatible with LED Driver serie LC flexC ADV;
not compatible with I-select (generation 1) and
I-select 2 (generation 2)
- Resistor is base isolated
- When using your own resistors, make sure the resistor must be
isolated
- Resistor power 0.25 W
- Current tolerance $\pm 2\%$ additional to output current tolerance
- Hot plug of the resistor is not permitted
- For detailed current setting see table "Specific technical data" of
the respective LED Driver and chapter 3.8 Current setting

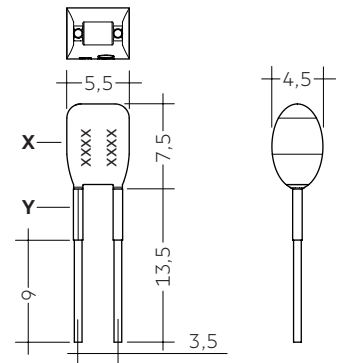

Ordering data

| Type | Article number | Colour of X area | Colour of Y area | Marking | Resistor value | Packaging bag | Weight per pc. |
|---------------------------|-----------------|------------------|------------------|---------|----------------|---------------|----------------|
| ADV Plug Type A YL | 28001771 | Yellow | Yellow | A | 0,0 Ω | 10 pc(s). | 0.001 kg |

1. Standards

EN 55015
EN 60598-1
EN 61000-3-2
EN 61000-3-3
EN 61347-1
EN 61347-2-13
EN 61547
EN 62384

1.1 Glow wire test

according to EN 61347-1 with increased temperature of 850 °C passed.

2. Thermal details and life-time

2.1 Expected life-time

| Expected life-time | | | | |
|------------------------------------|-----------|-----------|----------|----------|
| Type | Current | ta | 40 °C | 50 °C |
| LC 35W 700/800/1050mA flexC SR ADV | 700 mA | tc | 60 °C | 70 °C |
| | | Life-time | 50,000 h | 30,000 h |
| | 800 mA | tc | 65 °C | 75 °C |
| | | Life-time | 50,000 h | 30,000 h |
| 1,050 mA | tc | 65 °C | 75 °C | |
| | Life-time | 50,000 h | 30,000 h | |

The LED Driver is designed for a life-time stated above under reference conditions and with a failure probability of less than 10 %.

3. Installation / wiring

3.1 Circuit diagram

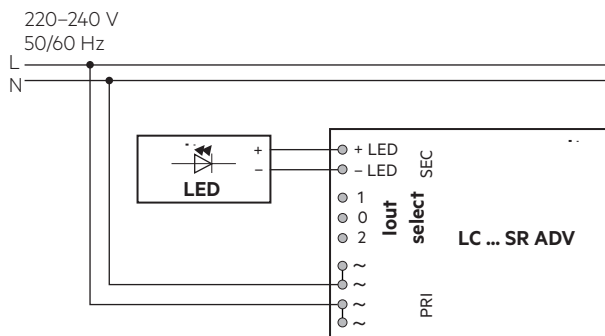

3.2 Wiring type and cross section

Mains supply wires

The wiring can be in stranded wires with ferrules or solid. For perfect function of the cage clamp terminals the strip length should be 4 – 5 mm for the input terminal. The max. torque at the clamping screw (M3) is 0.2 Nm.

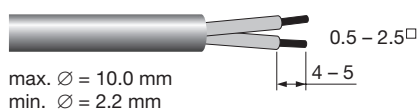

Secondary wires (LED module)

The output wiring can be done with a cross section of 0.5 – 1.5 mm². Strip 8.5 – 9.5 mm of insulation from the cables to ensure perfect operation of the push-wire terminals.

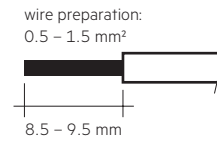

3.3 Loose wiring

Press down the “push button” and remove the cable from front.

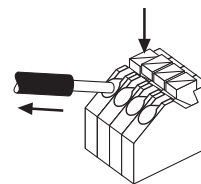

3.4 Fixing conditions

Dry, acidfree, oilfree, fatfree. It is not allowed to exceed the maximum ambient temperature (ta) stated on the device. Minimum distances stated below are recommendations and depend on the actual luminaire. Is not suitable for fixing in corner.

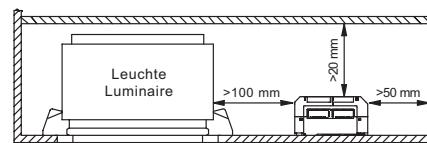

The LED module and all contact points within the wiring must be sufficiently insulated against 3 kV surge voltage.

3.5 Wiring guidelines

- All connections must be kept as short as possible to ensure good EMI behaviour.
- Mains leads should be kept apart from LED Driver and other leads (ideally 5 – 10 cm distance)
- Max. length of output wires is 2 m.
- The secondary wires (LED module) should be routed in parallel to ensure good EMC performance.
- Incorrect wiring can damage LED modules.
- To avoid the damage of the Driver, the wiring must be protected against short circuits to earth (sharp edged metal parts, metal cable clips, louver, etc.).
- The current selection has to be installed in the accordance to the requirement of low voltage installation.
- Through wiring of mains is for connecting additional LED Driver only. Max. permanent current of 13 A may not be exceeded.

3.6 Replace LED module

1. Mains off
2. Remove LED module
3. Wait for 20 seconds
4. Connect LED module again

Hot plug-in or output switching of LEDs is not permitted and may cause a very high current to the LEDs.

3.7 Current setting

700 mA: All terminals open

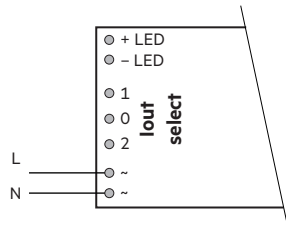

800 mA: Terminal 0 and 1 connected with 0 Ω wire (max. 6 cm length) or resistor ADV Plug Type A BR (article number: 28001771)

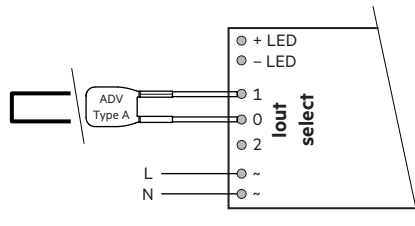

1,050 mA: Terminal 0 and 2 connected with 0 Ω wire (max. 6 cm length) or resistor ADV Plug Type A BR (article number: 28001771)

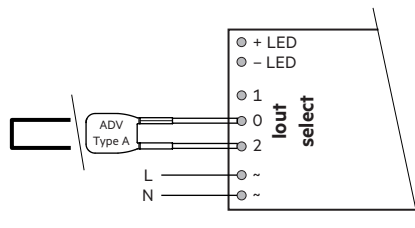

3.8 Mounting of device

Max. torque for fixing: 0.5 Nm/M4

4. Electrical values

Test at 230 V 50 Hz.

4.1 Efficiency vs load

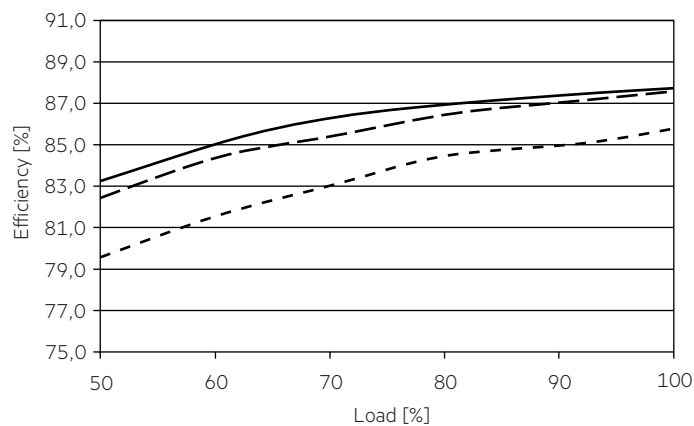

4.2 Power factor vs load

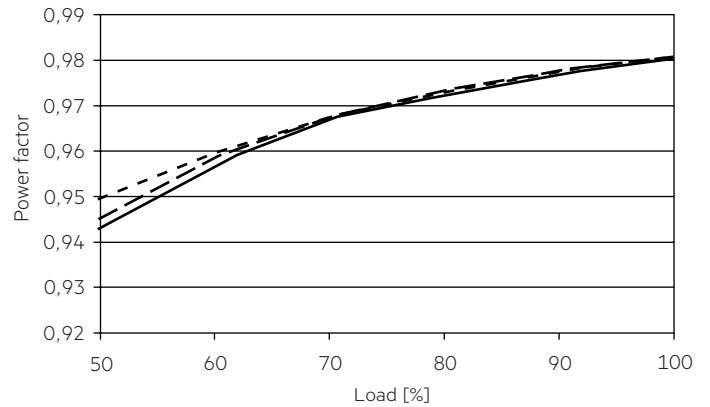

4.3 Input power vs load

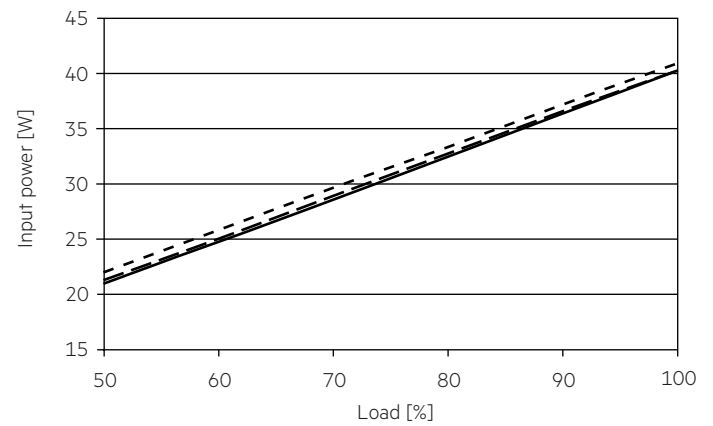

4.4 Input current vs load

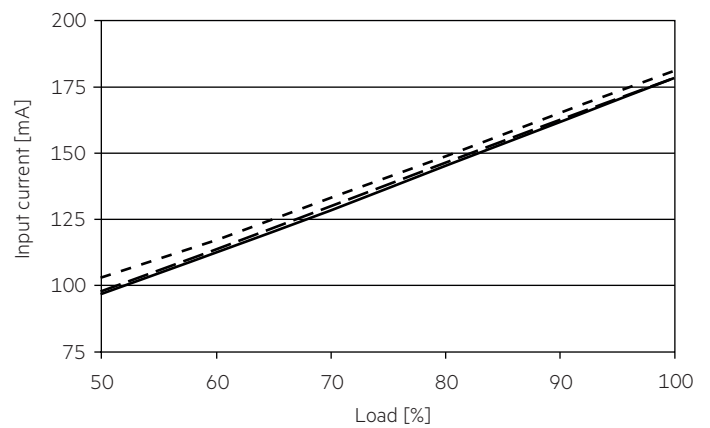

4.5 THD vs load

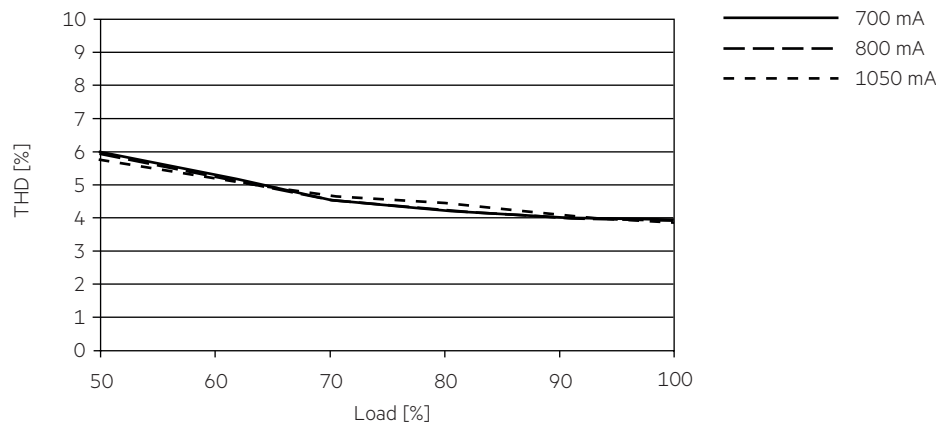

4.6 Maximum loading of automatic circuit breakers

| Automatic circuit breaker type | C10 | C13 | C16 | C20 | B10 | B13 | B16 | B20 | Inrush current |
|---|---------------------|---------------------|---------------------|---------------------|---------------------|---------------------|---------------------|---------------------|-----------------------|
| Installation Ø | 1.5 mm ² | 1.5 mm ² | 1.5 mm ² | 2.5 mm ² | 1.5 mm ² | 1.5 mm ² | 1.5 mm ² | 2.5 mm ² | I _{max} Time |
| LC 35W 700/800/1050mA flexC SR ADV | 40 | 51 | 63 | 80 | 24 | 31 | 38 | 48 | 15 A 230 µs |

4.7 Harmonic distortion in the mains supply (at 230 V / 50 Hz and full load) in %

| | THD | 3. | 5. | 7. | 9. | 11. |
|---|------|-----|-----|-----|-----|-----|
| LC 35W 700/800/1050mA flexC SR ADV | < 10 | < 6 | < 4 | < 3 | < 2 | < 2 |

5. Functions

5.1 Short-circuit behaviour

In case of a short circuit on the output side (LED) the LED Driver switches off. After elimination of the short-circuit fault the LED Driver will recover automatically.

5.2 No-load operation

The LED Driver works in burst working mode to provide a constant output voltage regulation which allows the application to be able to work safely when LED string opens due to a failure.

5.3 Overload protection

If the output voltage range is exceeded the LED Driver will protect itself and LED may flicker. After elimination of the overload, the nominal operation is restored automatically.

5.4 Over temperature protection

The LED Driver is protected against temporary thermal overheating. If the temperature limit is exceeded, the Driver switch off. It restarts automatically. The temperature protection is activated typically at 10 °C above t_c max.

6. Miscellaneous

6.1 Isolation and electric strength testing of luminaires

Electronic devices can be damaged by high voltage. This has to be considered during the routine testing of the luminaires in production.

According to IEC 60598-1 Annex Q (informative only!) or ENEC 303-Annex A, each luminaire should be submitted to an isolation test with 500 V_{DC} for 1 second. This test voltage should be connected between the interconnected phase and neutral terminals and the earth terminal. The isolation resistance must be at least 2 MΩ.

As an alternative, IEC 60598-1 Annex Q describes a test of the electrical strength with 1500 V_{AC} (or 1.414 x 1500 V_{DC}). To avoid damage to the electronic devices this test must not be conducted.

6.2 Conditions of use and storage

Humidity: 5 % up to max. 85 %, not condensed (max. 56 days/year at 85 %)

Storage temperature: -40 °C up to max. +80 °C

The devices have to be within the specified temperature range (t_a) before they can be operated.

6.3 Additional information

Additional technical information at www.tridonic.com → Technical Data

Guarantee conditions at www.tridonic.com → Services

Life-time declarations are informative and represent no warranty claim. No warranty if device was opened.