

30 W **Constant Current** LED driver

Product code: 5503

30 W 220 – 240 V 0 / 50 – 60 Hz

- High efficiency up to 88%
- Suitable for DC use
- Low current ripple, complying with IEEE 1789 standard
- Driver protection Class II
- Suitable for Class I and Class II luminaires
- For driving Class III (SELV) luminaires, optional strain reliefs available for independent use outside of luminaire (LC-SRA/LC1x30-SR or LC-SRA-LOOP for looping the input cables)
- *Optional version on request (55036): added lacquer coating provides improved robustness in challenging climate conditions (humidity, low temperature).*



Functional Description

- Selectable constant current output: 350 mA / 500 mA / 700 mA
- External NTC terminal for overtemperature protection
- Open & short circuit protection

Mains Characteristics

Voltage range	198 VAC – 264 VAC
	Withstands max. 320 VAC (max. 1 hour)
DC range	176 VDC – 280 VDC
starting voltage	> 190 VDC
Mains current at full load	0.14 – 0.18 A
Frequency	0 / 50 Hz – 60 Hz
THD at full power	< 15 %
Tested surge protection	1 kV L-N, 2 kV L-GND (IEC 61000-4-5)
Tested fast transient protection	4 kV (IEC 61000-4-4)

Insulation between circuits & driver case

Mains circuit - SELV circuit	Double/reinforced insulation
Mains and output - Driver case	Double/reinforced insulation

Load Output (SELV < 120 V)

Output current (I_{out})	350 mA / 500 mA / 700 mA
Accuracy	$\pm 5 \%$
Ripple	< 2 %* at ≤ 120 Hz
	*] Low frequency, LED load: Cree XM-L LEDs
U_{OUT} (max) (abnormal)	80 V

I_{LED}	350 mA	500 mA	700 mA
P_{RATED}	21 W	30 W	30 W
U_{LED}	10 – 60 V	10 – 60 V	10 – 43 V
PF (λ) at full load	0.93	0.96	0.96
Efficiency (η) at full load	88 %	88 %	87 %

Operating window

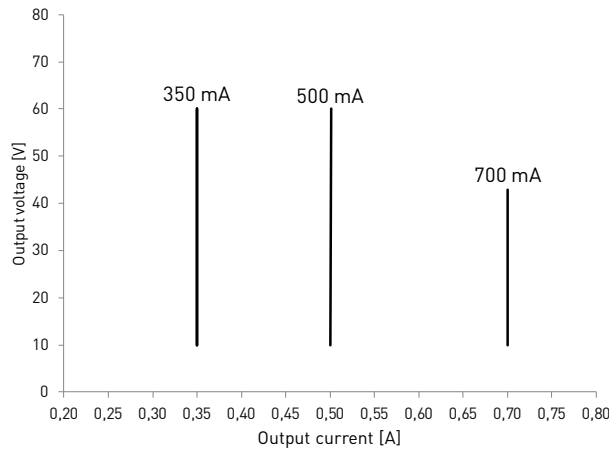

Driver performance

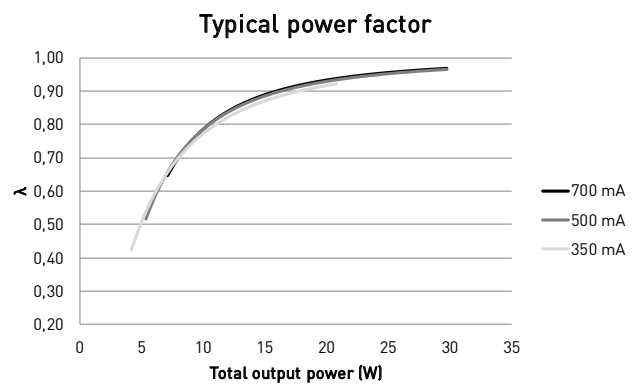
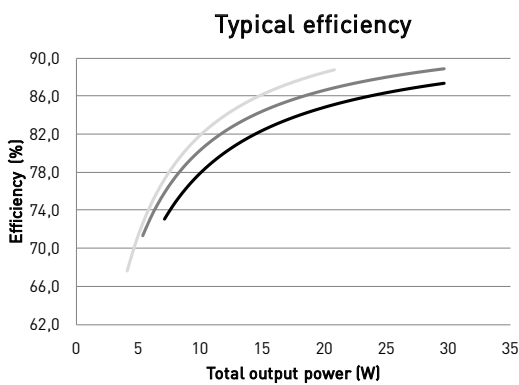

Operating Conditions and Characteristics

- Highest allowed t_c point temperature: 75 °C
- Ambient temperature range^{*/**}: -20 °C ... +50 °C
- in independent use: -20 °C ... +45 °C
- Storage temperature range: -40 °C ... +80 °C
- Maximum relative humidity: No condensation^{**}
- Lifetime (90 % survival rate): 100 000 h, at $t_c = 65$ °C
- 75 000 h, at $t_c = 70$ °C
- 50 000 h at $t_c = 75$ °C

^{*}) For other than independent use, higher t_s of the control gear possible as long as highest allowed t_c point temperature is not exceeded

^{**}) Coated version: partially allowed condensation, $T_a = -40.. +50$ °C

Quantity of drivers per miniature circuit breaker 16 A Type C

Based on I_{cont}	Based on inrush current I_{peak}	Typ. peak inrush current I_{peak}	1/2 value time, Δt	Calculated energy, $I_{peak}^2 \Delta t$
74 pcs.	1742 pcs.	7 A	25 μ s	0.00090 A ² s

CONVERSION TABLE FOR OTHER TYPES OF MINIATURE CIRCUIT BREAKER

MCB type	Relative quantity of LED drivers
B 10 A	37 %
B 16 A	60 %
B 20 A	75 %
C 10 A	62 %
C 16 A	100 % (see table above)
C 20 A	125 %

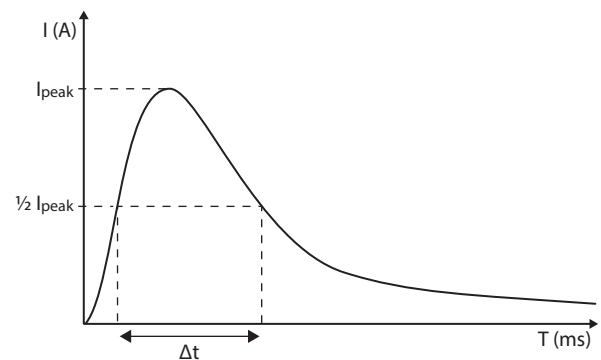

Type C MCB's are strongly recommended to use with LED lighting. Please see more details in "MCB information" document in each driver product page in "downloads & links" section.

Connections and Mechanical Data

Wire size	0.5 mm ² – 1.5 mm ²
Wire type	Solid core and fine-stranded
Wire insulation	According to EN 60598
Maximum driver to LED wire length	5 m (1 m with NTC)
Weight	115 g
NTC trigger point	8.2 kΩ
IP rating	IP20

Connections

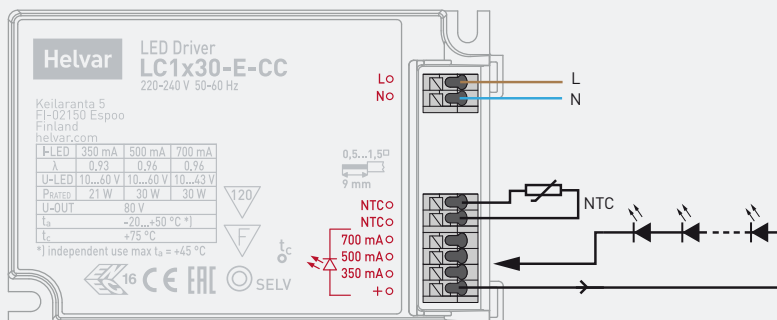

Note:

- Not suitable for load side switching operation.

Dimensions (mm)

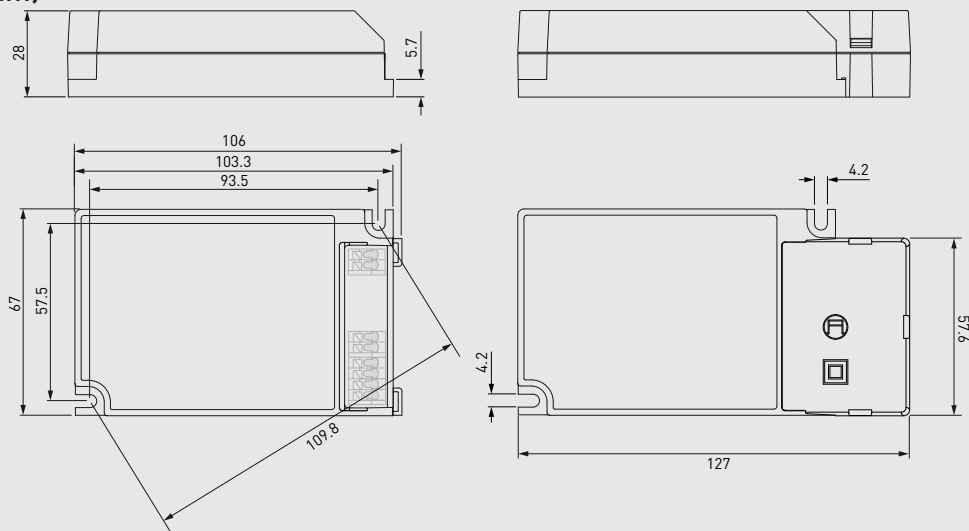

LC1x30-E-CC LED driver is suited for built-in usage in luminaires. With LC1x30-SR/LC-SRA/LC-SRA-LOOP strain reliefs, independent use is possible too. In order to have safe and reliable LED driver operation, the LED luminaires will need to comply with the relevant standards and regulations (e.g. IEC/EN 60598-1). The LED luminaire shall be designed to adequately protect the LED driver from dust, moisture and pollution. The luminaire manufacturer is responsible for the correct choice and installation of the LED drivers according to the application and product datasheets. Operating conditions of the LED drivers may never exceed the specifications as per the product datasheet.

Installation & operation

Maximum ambient and t_c temperature:

- For built-in components inside luminaires, the t_a ambient temperature range is a guideline given for the optimum operating environment. However, integrator must always ensure proper thermal management (i.e. mounting base of the driver, air flow etc.) so that the t_c point temperature does not exceed the t_c maximum limit in any circumstance.
- Reliable operation and lifetime is only guaranteed if the maximum t_c point temperature is not exceeded under the conditions of use.

Current setting

LC1x30-E-CC driver features three separate constant current outputs selectable via current output terminals.

Miniature Circuit Breakers (MCB)

- Type-C MCB's with trip characteristics in according to EN 60898 are recommended.
- Please see more details in "MCB information" document in each driver product page in "downloads & links" section.

Installation site

- The general preferred installation position of LED drivers for independent use is to have the top cover facing upwards.

Lamp failure functionality

No load

When open load is detected, driver limits output voltage according to $U_{out} (max)$ (abnormal).

Overload

Reliable operation of the driver is only guaranteed in specified voltage range.

Underload

Reliable operation of the driver is only guaranteed in specified voltage range.

Short circuit

Driver can withstand output short circuit.

Conformity & standards

General and safety requirements	EN 61347-1
Particular safety requirements for DC or AC supplied electronic control gear for LED modules	EN 61347-2-13
Thermal protection class	EN 61347, C5e
Mains current harmonics	EN 61000-3-2
Limits for voltage fluctuations and flicker	EN 61000-3-3
Radio frequency interference	EN 55015
Immunity standard	EN 61547
Performance requirements	EN 62384
Recommended Practices for Modulating Current in High-Brightness LEDs for Mitigating Health Risks to Viewers	IEEE 1789-2015
Compliant with relevant EU directives	
RoHS/REACH compliant	
ENEC and CE marked	

Label symbols



Double insulated control gear suitable for built-in use.



Thermally controlled control gear, incorporating means of protection against overheating to prevent the case temperature under any conditions of use from exceeding 120 °C.



Control gear suitable for direct mounting on normally flammable surfaces, with or without thermally insulating material. Normally flammable surfaces are defined to include building materials such as wood, and materials based on wood, of more than 2 mm thickness.