



**Driver LCA 150W 24V one4all SC PRE**  
PREMIUM series

**Product description**

- Dimmable 24 V constant voltage LED Driver for flexible constant voltage strips
- One4all interface and ready2mains enable different dimming options
- Dimming range 1 to 100 %
- No additional external dimmer is needed
- Suitable for emergency escape lighting systems acc. to EN 50172
- Nominal life-time up to 50,000 h
- 5-year guarantee

**Typical application**

- Cove lighting, facade accent lighting, ceiling integration

**Technical details**

- 24 V, 150 W
- Small design (325 x 43 x 30 mm) with stretched-compact strain relief
- Small cross section
- Push terminal for simple wiring
- 2 output channels (+/-) for more flexibility in the application

**Interfaces**

- one4all (DALI DT 6, DSI, switchDIM, corridorFUNCTION)
- ready2mains (configuration and dimming via mains)
- Terminal blocks: 45° push terminals

**System solution**

- Tridonic LLE-FLEX ADV 600, 1,200, 1,800 lm/m
- Tridonic LLE-FLEX EXC 600, 1,200, 1,800, 2,500 lm/m
- In connection with Flex accessories wire to PCB plug



**Standards**, page 3

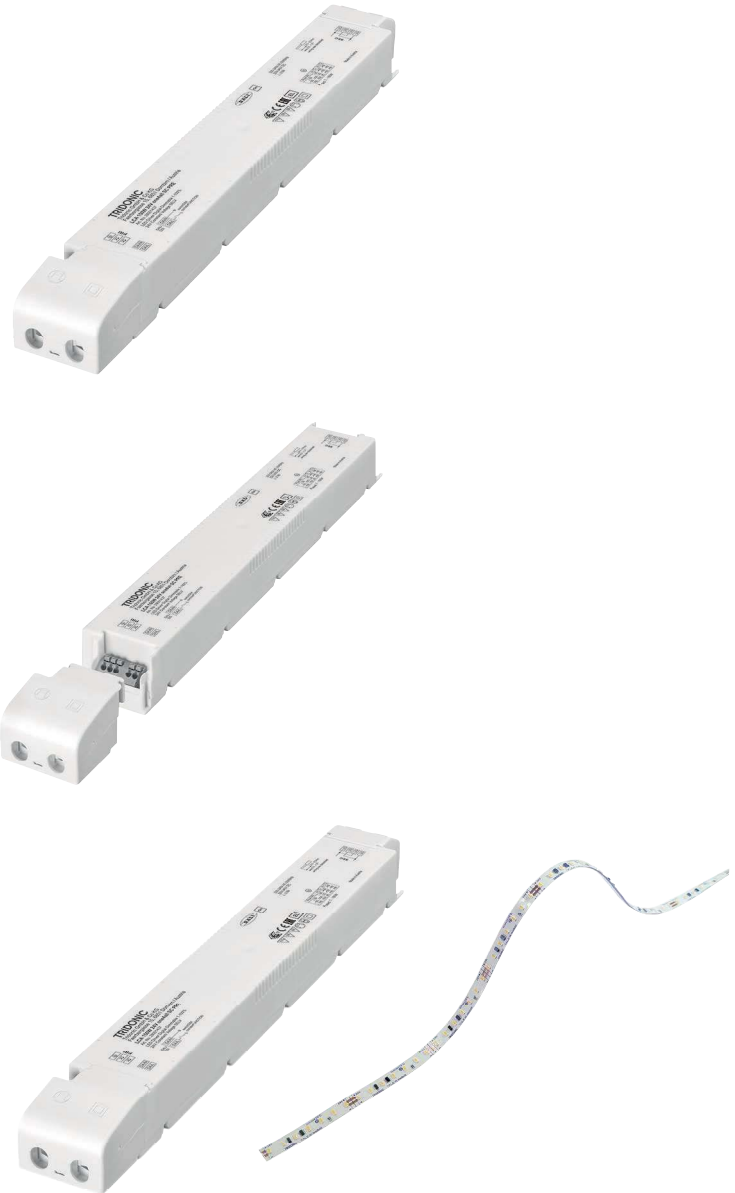

System solution

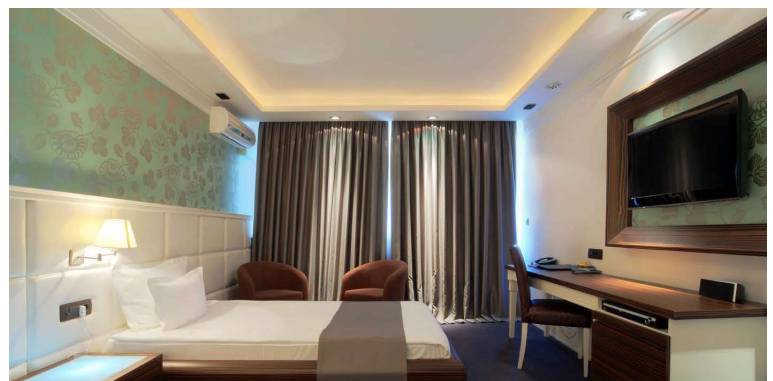

IP20 SELV RoHS

### Driver LCA 150W 24V one4all SC PRE

PREMIUM series

#### Technical data

|   |                    |
|---|--------------------|
| Rated supply voltage                                      | 220 – 240 V        |
| AC voltage range  | 198 – 264 V        |
| DC voltage range  | 176 – 280 V        |
| Mains frequency   | 0 / 50 / 60 Hz     |
| Typ. current (at 230 V, 50 Hz, full load) <sup>①</sup>    | 710 mA             |
| Typ. current (220 V, 0 Hz, full load, 15 % dimming level) | 129 mA             |
| Leakage current (at 230 V, 50 Hz, full load) <sup>①</sup> | < 320 µA           |
| Max. input power  | 160 W              |
| Typ. efficiency (at 230 V / 50 Hz / full load)            | 94 %               |
| λ (at 230 V, 50 Hz, full load) <sup>①</sup>               | 0.99               |
| Typ. power input on stand-by <sup>②</sup>                 | < 0.44 W           |
| Typ. input current in no-load operation                   | 66.4 mA            |
| Typ. input power in no-load operation <sup>②</sup>        | 2.5 W              |
| In-rush current (peak / duration)                         | 60.2 A / 195 µs    |
| THD (at 230 V, 50 Hz, full load) <sup>①</sup>             | < 4.3 %            |
| Time to light (at 230 V, 50 Hz, full load) <sup>①</sup>   | < 0.63 s           |
| Time to light (DC mode)                                   | < 0.32 s           |
| Switchover time (AC/DC)                                   | < 0.32 s           |
| Turn off time (at 230 V, 50 Hz, full load)                | < 8 ms             |
| Output voltage tolerance                                  | ± 1 V              |
| Output LF voltage ripple (< 120 Hz)                       | ± 5 %              |
| Max. output voltage (no-load voltage)                     | 60 V               |
| PWM frequency   | ~ 1 kHz            |
| Dimming range   | 1 – 100 %          |
| Mains surge capability (between L – N)                    | 1 kV               |
| Mains surge capability (between L/N – PE)                 | 2 kV               |
| Dimensions L x W x H                                      | 325 x 43 x 29.8 mm |

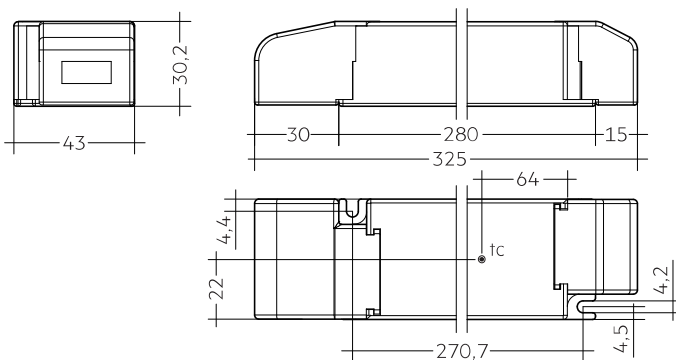

#### Ordering data

| Type                                  | Article number  | Packaging carton <sup>®</sup> | Packaging pallet | Weight per pc. |
|---------------------------------------|-----------------|-------------------------------|------------------|----------------|
| <b>Multi packaging</b>                |                 |                               |                  |                |
| <b>LCA 150W 24V one4all SC PRE</b>    | <b>28001437</b> | 10 pc(s).                     | 390 pc(s).       | 0.298 kg       |
| <b>Single packaging</b>               |                 |                               |                  |                |
| <b>LCA 150W 24V one4all SC PRE SP</b> | <b>28001923</b> | 10 pc(s).                     | 240 pc(s).       | 0.298 kg       |

<sup>®</sup> The strain relief is included in both packaging variants.

In the single packaging each Driver has also an individual packaging.

#### Specific technical data

| Type                               | Load  | Forward voltage | Output current | Max. output power (at 24 V, full load) | Typ. power consumption (at 24 V, full load) | Typ. current consumption (at 24 V, full load) | Max. casing temperature tc | Ambient temperature ta max. |
|------------------------------------|-------|-----------------|----------------|--|---|---|----------------------------|-----------------------------|
| <b>LCA 150W 24V one4all SC PRE</b> | 10 %  | 24 V            | 0.625 A        | 15 W                                   | 191 W                                       | 122 mA  | 80 °C                      | -25 ... +60 °C              |
|                                    | 20 %  | 24 V            | 1.250 A        | 30 W                                   | 34.3 W                                      | 174 mA  | 80 °C                      | -25 ... +60 °C              |
|                                    | 30 %  | 24 V            | 1.875 A        | 45 W                                   | 49.7 W                                      | 235 mA  | 80 °C                      | -25 ... +60 °C              |
|                                    | 40 %  | 24 V            | 2.500 A        | 60 W                                   | 65.2 W                                      | 298 mA  | 85 °C                      | -25 ... +55 °C              |
|                                    | 50 %  | 24 V            | 3.125 A        | 75 W                                   | 80.7 W                                      | 364 mA  | 85 °C                      | -25 ... +55 °C              |
|                                    | 60 %  | 24 V            | 3.750 A        | 90 W                                   | 96.3 W                                      | 430 mA  | 85 °C                      | -25 ... +55 °C              |
|                                    | 70 %  | 24 V            | 4.375 A        | 105 W                                  | 112.1 W                                     | 498 mA  | 90 °C                      | -25 ... +50 °C              |
|                                    | 80 %  | 24 V            | 5.000 A        | 120 W                                  | 127.7 W                                     | 565 mA  | 90 °C                      | -25 ... +50 °C              |
|                                    | 90 %  | 24 V            | 5.625 A        | 135 W                                  | 143.3 W                                     | 633 mA  | 90 °C                      | -25 ... +50 °C              |
|                                    | 100 % | 24 V            | 6.250 A        | 150 W                                  | 159.3 W                                     | 702 mA  | 90 °C                      | -25 ... +50 °C              |

<sup>①</sup> Valid at 100 % dimming level.

<sup>②</sup> Depending on the DALI traffic at the interface.

## 1. Standards

EN 55015  
 EN 61000-3-2  
 EN 61000-3-3  
 EN 61347-1  
 EN 61347-2-13  
 EN 62384  
 EN 61547  
 EN 62386-101 (according to DALI standard V2)  
 EN 62386-102  
 EN 62386-207  
 According to EN 50172 for use in central battery systems  
 According to EN 60598-2-22 suitable for emergency lighting installations

### 1.1 Glow wire test

according to EN 61347-1 with increased temperature of 850 °C passed.

## 2. Thermal details and life-time

### 2.1 Expected life-time

| Expected lifetime           |             |           |            |            |            |          |          |
|-----------------------------|-------------|-----------|------------|------------|------------|----------|----------|
| Type                        | Output load | ta        | 40 °C      | 45 °C      | 50 °C      | 55 °C    | 60 °C    |
| LCA 150W 24V one4all SC PRE | 100 – 150 W | tc        | 80 °C      | 80 °C      | 90 °C      |          |          |
|                             |             | Life-time | 95,000 h   | 75,000 h   | 55,000 h   |          |          |
|                             | 50 – 100 W  | tc        | 65 °C      | 70 °C      | 75 °C      | 85 °C    |          |
|                             |             | Life-time | >100,000 h | >100,000 h | 80,000 h   | 60,000 h |          |
|                             | < 50 W      | tc        | 55 °C      | 60 °C      | 65 °C      | 70 °C    | 80 °C    |
|                             |             | Life-time | >100,000 h | >100,000 h | >100,000 h | 80,000 h | 60,000 h |

The LED control gear is designed for a life-time stated above under reference conditions and with a failure probability of less than 10 %.

The relation of tc to ta temperature depends also on the luminaire design.

If the measured tc temperature is approx. 5 K below tc max., ta temperature should be checked and eventually critical components (e.g. ELCAP) measured. Detailed information on request.

## 3. Installation / wiring

### 3.1 Circuit diagram

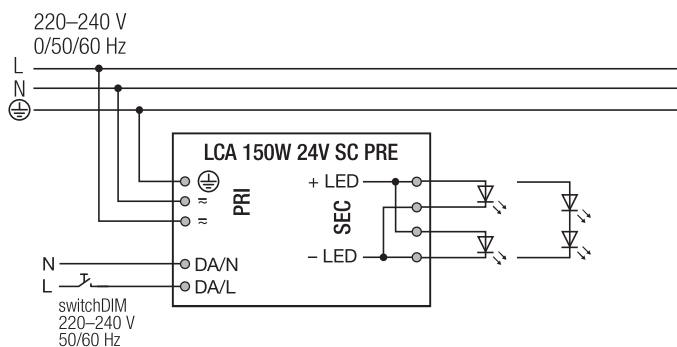
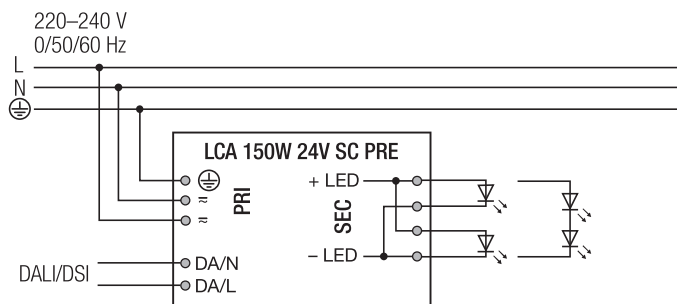

### 3.2 Mains supply wiring

The wiring can be in stranded wires with ferrules or solid from 0.5 – 1.5 mm<sup>2</sup>. For perfect function of the push-wire terminals (WAGO 250) the strip length should be 8.5 – 9.5 mm.

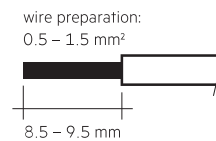

Secondary strain relief for cables with bigger cable sheath

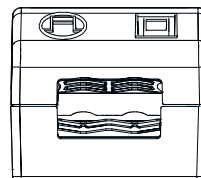

Secondary strain relief for cable with smaller cable sheath

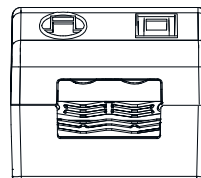

### 3.3 Loose wiring

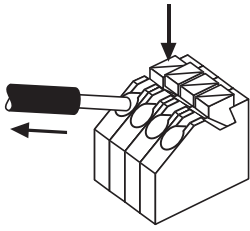

#### Release of the wiring

Press down the “push button” and remove the cable from front.

### 3.4 Fixing conditions when using as independent Driver with Clip-On

Dry, acidfree, oilfree, fatfree. It is not allowed to exceed the maximum ambient temperature ( $t_a$ ) stated on the device. Minimum distances stated below are recommendations and depend on the actual luminaire. Is not suitable for fixing in corner.

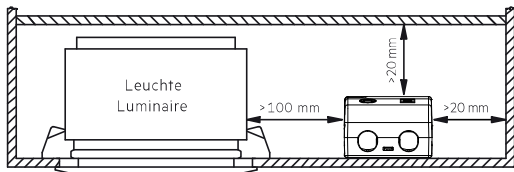

### 3.5 Wiring guidelines

- The cables should be run separately from the mains connections and mains cables to ensure good EMC conditions.
- The LED wiring should be kept as short as possible to ensure good EMC. The max. secondary cable length is 2 m (4 m circuit).
- Secondary switching is not permitted.
- The LED Driver has no inverse-polarity protection on the secondary side. Wrong polarity can damage LED modules with no inverse-polarity protection.
- Wrong wiring of the LED Driver can lead to malfunction or irreparable damage.

### 3.6 Hot plug-in

Hot plug-in is not supported due to residual output voltage of  $> 0$  V. If a LED load is connected the device has to be restarted before the output will be activated again. This can be done via mains reset or via interface (DALI, DSI, switchDIM, ready2mains).

### 3.7 Earth connection

The earth connection is conducted as protection earth (PE). The LED Driver can be earthed via earth terminal. If the LED Driver will be earthed, protection earth (PE) has to be used. There is no earth connection required for the functionality of the LED Driver. Earth connection is recommended to improve following behaviour:

- Electromagnetic interferences (EMI)
- LED glowing at standby
- Transmission of mains transients to the LED output

In general it is recommended to earth the LED Driver if the LED module is mounted on earthed luminaire parts respectively heat sinks and thereby representing a high capacity against earth.

## 4. Electrical values

### 4.1 Efficiency vs. load

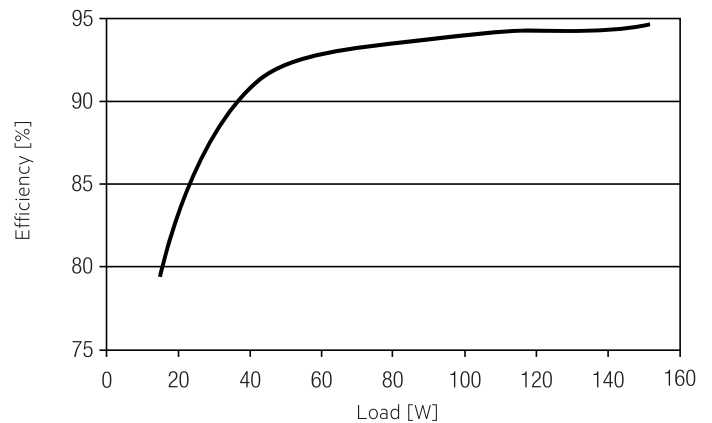

### 4.2 Power factor vs. Load

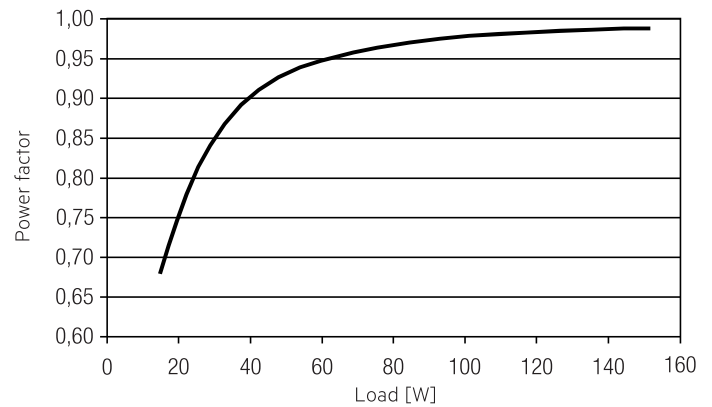

### 4.3 Input power vs. Load

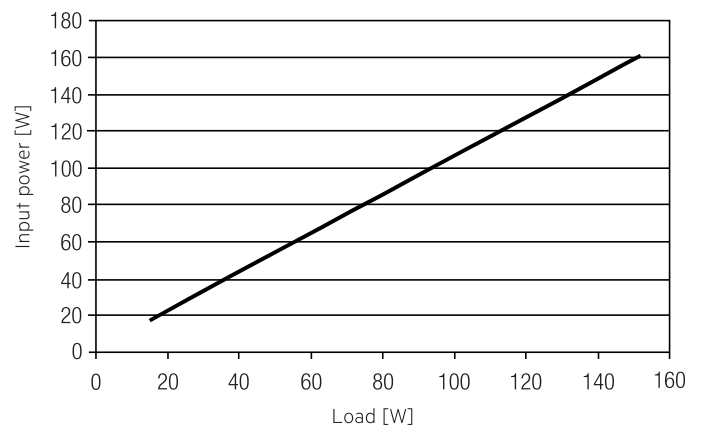

#### 4.4 Input current vs. Load

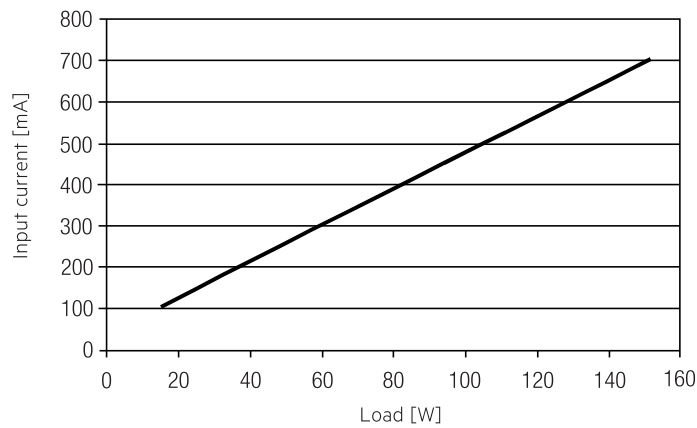

#### 4.5 THD vs. Load

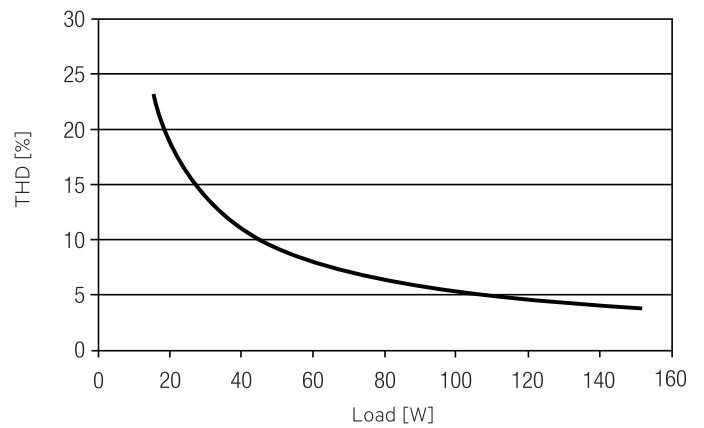

#### 4.6 Maximum loading of automatic circuit breakers

| Automatic circuit breaker type     | C10                 | C13                 | C16                 | C20                 | B10                 | B13                 | B16                 | B20                 | Inrush current        |
|------------------------------------|---------------------|---------------------|---------------------|---------------------|---------------------|---------------------|---------------------|---------------------|-----------------------|
| Installation Ø                     | 1.5 mm <sup>2</sup> | 1.5 mm <sup>2</sup> | 2.5 mm <sup>2</sup> | 2.5 mm <sup>2</sup> | 1.5 mm <sup>2</sup> | 1.5 mm <sup>2</sup> | 2.5 mm <sup>2</sup> | 2.5 mm <sup>2</sup> | I <sub>max</sub> time |
| <b>LCA 150W 24V one4all SC PRE</b> | 7                   | 8                   | 10                  | 13                  | 4                   | 5                   | 6                   | 8                   | 60.2 A 195 µs         |

Typical values for MCB from ABB series S200 as reference.  
Actual values can differ due to used MCB types and installation environment.

#### 4.7 Harmonic distortion in the mains supply (at 230 V / 50 Hz and full load) in %

|                                    | THD | 3. | 5. | 7. | 9. | 11. |
|------------------------------------|-----|----|----|----|----|-----|
| <b>LCA 150W 24V one4all SC PRE</b> | 4   | 4  | 3  | 1  | 1  | 1   |

#### 4.8 Dimming

- Dimming range 1% to 100 %  
Digital control with:
- DSI signal: 8 bit Manchester Code  
Speed 1% to 100% in 1.4 s
  - DALI signal: 16 bit Manchester Code  
Speed 1% to 100% in 0.2 s  
Programmable parameter:  
Minimum dimming level  
Maximum dimming level  
Default minimum = 1%  
Programmable range 1% ≤ MIN ≤ 100 %  
Default maximum = 100 %  
Programmable range 100% ≥ MAX ≥ 1%

Dimming is realized by PWM dimming.

#### 4.9 Dimming characteristics

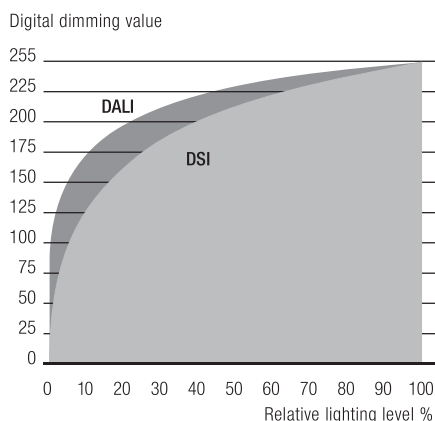

Dimming characteristics as seen by the human eye

## 5. Interfaces / communication

### 5.1 Control input (DA/N, DA/L)

Digital DALI signal or switchDIM can be wired on the same terminals (DA/N and DA/L).

The control input is non-polar for digital control signals (DALI, DSI). The control signal is not SELV. Control cable has to be installed in accordance to the requirements of low voltage installations. Different functions depending on each module.

### 5.2 switchDIM

Integrated switchDIM function allows a direct connection of a pushbutton for dimming and switching.  
Brief push (< 0.6 s) switches LED control gear ON and OFF. The dimm level is saved at power-down and restored at power-up.  
When the pushbutton is held, LED modules are dimmed. After repush the LED modules are dimmed in the opposite direction.  
In installations with LED control gears with different dimming levels or opposite dimming directions (e.g. after a system extension), all LED control gears can be synchronized to 50% dimming level by a 10 s push.  
Use of pushbutton with indicator lamp is not permitted.

### 5.3 Light level in DC operation

The LED Driver is designed for operation on DC voltage and pulsed DC voltage.

Light output level in DC operation: programmable 1 – 100 % (EOFu = 0.13).  
Programming by DALI or ready2mains.  
In DC operation dimming mode can be activated.

The voltage-dependent input current of Driver incl. LED module is depending on the used load.

The voltage-dependent no-load current of Driver (without or defect LED module) is for:

- AC: < 66 mA
- DC: < 35 mA

## 6. Functions

### 6.1 ready2mains – configuration

The ready2mains interface can be used to configure the main parameters of LED Drivers via the mains wiring, such as CLO and DC level. These parameters can be adjusted either via ready2mains-capable configuration software or directly via the ready2mains programmer.

### 6.2 ready2mains – dimming

ready2mains allows for mains-based group dimming, controlled via the ready2mains protocol and appropriate dimming interfaces.

For details on the operation of ready2mains and its components see the relevant technical information.

### 6.3 Short-circuit behaviour

In case of a short-circuit at the LED output the LED output is switched off. After restart of the LED Driver the output will be activated again. The restart can either be done via mains reset or via interface (DALI, DSI, switchDIM, ready2mains). Open circuit lamp failure is not recognized.

### 6.4 Overload protection

If the max. output current or the max. output power is exceeded the LED Driver turns off the LED output. After restart of the LED Driver the output will be activated again. The restart can either be done via mains reset or via interface (DALI, DSI, switchDIM, ready2mains).

### 6.5 Overtemperature protection

The LED Driver is protected against temporary thermal overheating. If the temperature limit is exceeded the LED Driver will be dimmed. The temperature protection is activated approx. +5 °C above  $t_{c\ max}$  (see page 2). On DC operation this function is deactivated to fulfill emergency requirements.

### 6.6 corridorFUNCTION

The corridorFUNCTION can be programmed in two different ways. To program the corridorFUNCTION by means of software a DALI-USB interface is needed in combination with a DALI PS. The software can be the masterCONFIGURATOR.

To activate the corridorFUNCTION without using software a voltage of 230 V has to be applied for five minutes at the switchDIM connection. The unit will then switch automatically to the corridorFUNCTION.

Note:

If the corridorFUNCTION is wrongly activated in a switchDIM system (for example a switch is used instead of pushbutton), there is the option of installing a pushbutton and deactivating the corridorFUNCTION mode by five short pushes of the button within three seconds.

switchDIM and corridorFUNCTION are very simple tools for controlling gears with conventional pushbuttons or motion sensors.

To ensure correct operation a sinusoidal mains voltage with a frequency of 50 Hz or 60 Hz is required at the control input.

Special attention must be paid to achieving clear zero crossings. Serious mains faults may impair the operation of switchDIM and corridorFUNCTION.

### 6.7 Constant light output (CLO)

The luminous flux of an LED decreases constantly over the life-time. The CLO function ensures that the emitted luminous flux remains stable. For that purpose the LED current will increase continuously over the LED life-time. In masterCONFIGURATOR it is possible to select a start value (in percent) and an expected life-time. The LED Driver adjusts the current afterwards automatically.

### 6.8 Power-up/-down fading

The power-up/-down function offers the opportunity to modify the on-/off behavior. The time for fading on or off can be adjusted in a range of 0.2 to 16 seconds. According to this value, the device dims either from 0 % up to the power-on level or from the current set dim level down to 0 %. This feature applies while operating via switchDIM, ready2mains and when switching the mains voltage on or off. By factory default no fading time is set (= 0 seconds).

### 6.9 Light level in DC operation

Programmable from 1 – 100 %  
Programming by extended DSI or DALI signal (16 bit).  
Light output level in DC operation ( $EOF_{DC}$ ): 0.13 (cannot be adjusted).  
In DC operation dimming mode can be activated.

### 6.10 Software / programming

With appropriate software and a interface different functions can be activated and various parameters can be configured in the LED Driver. To do so, a DALI-USB or ready2mains programmer and the software (masterCONFIGURATOR) are required.

### 6.11 masterCONFIGURATOR

From version 2.8:

For programming functions (CLO, power-up fading, corridorFUNCTION) and device settings (fade time, ePowerOnLevel, DC level, etc.).

For further information see masterCONFIGURATOR manual.

## 6.12 deviceCONFIGURATOR

PC (windows) based software application to transfer parameters into our drivers.

Workflow optimised for the use in OEM production line.

For further information see deviceCONFIGURATOR manual.

## 7. Miscellaneous

### 7.1 Isolation and electric strength testing of luminaires

Electronic devices can be damaged by high voltage. This has to be considered during the routine testing of the luminaires in production.

According to IEC 60598-1 Annex Q (informative only!) or ENEC 303-Annex A, each luminaire should be submitted to an isolation test with 500 V<sub>DC</sub> for 1 second. This test voltage should be connected between the interconnected phase and neutral terminals and the earth terminal.

The isolation resistance must be at least 2MΩ.

As an alternative, IEC 60598-1 Annex Q describes a test of the electrical strength with 1500 V<sub>AC</sub> (or 1.414 x 1500 V<sub>DC</sub>). To avoid damage to the electronic devices this test must not be conducted.

### 7.2 Conditions of use and storage

Environmental conditions: 5% up to max. 85%,  
not condensed  
(max. 56 days/year at 85%)

Storage temperature: -40 °C up to max. +80 °C

The devices have to be acclimatised to the specified temperature range (ta) before they can be operated.

### 7.3 Additional information

Additional technical information at [www.tridonic.com](http://www.tridonic.com) → Technical Data

Guarantee conditions at [www.tridonic.com](http://www.tridonic.com) → Services

Life-time declarations are informative and represent no warranty claim.

No warranty if device was opened.