



#### EM powerLED BASIC FX 80 W

Combined emergency lighting LED Driver

#### Product description

- Fixed-output LED Driver for mains operation with integrated Simple CORRIDOR FUNCTION (CF)
- Emergency lighting LED Driver with manual test function
- For self-contained emergency lighting
- For LED modules with a forward voltage of 50 – 230 V in mains operation
- For LED modules with a forward voltage of 50 – 200 V in emergency operation
- For luminaire installation
- Low-profile casing (21 x 30 mm cross-section)
- 5 years guarantee



#### Properties

- 25 – 80 W output power
- Constant current LED operation
- 150 – 500 mA output current in mains operation selectable with I-SELECT PLUG in steps of 25 mA
- Simple CORRIDOR FUNCTION (CF) with 10 % light level
- Integrated emergency lighting unit
- 1 or 3 h rated duration selectable with plug (duration link)
- Standard or High output selectable with plug (output link)
- Automatic shutdown of output if LED load is out of range
- Green charge status display LED
- Electronic charge system
- Polarity reversal protection for battery
- Deep discharge protection
- Short-circuit-proof battery connection



#### Batteries

- High-temperature cells
- NiCd or NiMH batteries
- D-, Cs- or LA cells
- 4-year design life
- 1-year guarantee
- For battery compatibility refer to table „Battery selection“



**Standards**, page 9

**Wiring diagrams and installation examples**, page 12



### EM powerLED BASIC FX 80 W

Combined emergency lighting LED Driver

#### Technical data

Rated supply voltage	220 – 240 V
Mains frequency	50 / 60 Hz
Typ. $\lambda$ (at 230 V, 50 Hz, normal operation)	0.97
Typ. $\lambda$ (at 230 V, 50 Hz, CF operation)	0.65
Leakage current (PE)	< 0.5 mA
Overvoltage protection	320 V (for 1 h)
Battery charging time	24 h
Max. open circuit voltage	250 V
Time to light	< 0.5 s from detection of emergency event
Typ. power consumption in charging	4 W
Output LF current ripple (< 120 Hz)	< 2 %
Output current tolerance	$\pm$ 7 %
THD normal operation	< 10 %
THD CF operation	< 25 %
Ambient temperature $t_a \leq 65$ W	-5 ... +55 °C
Ambient temperature $t_a > 65$ W	-5 ... +50 °C
Max. casing temperature $t_c$	80 °C
Dimensions LxBxH	360 x 30 x 21 mm
Mains voltage changeover threshold	according to EN 60598-2-22
Type of protection	IP20
Charge current 1h	100 mA
Charge current 3h	200 mA
Discharge current 1h	840 mA
Discharge current 3h	840 mA

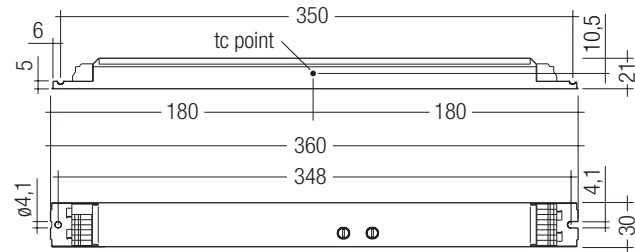

Note: LED Driver supplied with duration link in 3 hours position and standard/high output link in standard output position. Remove duration link for 1 hour duration. Remove standard/high output link for high output configuration. Duration link, standard/high output link and I-SELECT PLUG must be set before battery and mains connection.

#### Ordering data

Type®	Article number	Rated duration	Number of cells	Packaging, carton	Packaging, pallet	Weight per pc.
EM powerLED BASIC FX 104 LP 80W 200V	89800393	1/3 h	4/5	10 pc(s).	600 pc(s).	0.275 kg

## Specific technical data

Type <sup>①</sup>	Number of battery cells	Output current	Min. output voltage <sup>③</sup>	Max. output voltage <sup>③</sup>	Min. output power	Max. output power	Input power (at 230 V, 50 Hz, full load)	Input current (at 230 V, 50 Hz, full load)	Efficiency (at 230 V, 50 Hz) <sup>①</sup>	$\lambda$ (at 230 V, 50 Hz, full load)	Ambient temperature $t_a$ <sup>②</sup>	$t_c/t_a$ for $\geq 50,000$ h <sup>②</sup>	I sel resistor value
<b>Normal operation</b>													
<b>EM powerLED BASIC FX 104 LP 80W 200V</b>	-	150 mA	168 V	230 V	25 W	34.5 W	40 W	200 mA	86 %	0.85	-5 ... +55 °C	78 / 55 °C	open
	-	175 mA	142 V	230 V	25 W	40.3 W	46 W	225 mA	90 %	0.90	-5 ... +55 °C	78 / 55 °C	64.90 k $\Omega$
	-	200 mA	126 V	230 V	25 W	46.0 W	52 W	250 mA	92 %	0.90	-5 ... +55 °C	78 / 55 °C	56.00 k $\Omega$
	-	225 mA	111 V	230 V	25 W	51.8 W	58 W	275 mA	93 %	0.90	-5 ... +55 °C	78 / 55 °C	48.70 k $\Omega$
	-	250 mA	100 V	230 V	25 W	57.5 W	65 W	300 mA	93 %	0.95	-5 ... +55 °C	78 / 55 °C	43.20 k $\Omega$
	-	275 mA	90 V	230 V	25 W	63.3 W	70 W	325 mA	93 %	0.97	-5 ... +55 °C	78 / 55 °C	36.50 k $\Omega$
	-	300 mA	83 V	230 V	25 W	69.0 W	76 W	350 mA	93 %	0.97	-5 ... +50 °C	78 / 50 °C	32.40 k $\Omega$
	-	325 mA	76 V	230 V	25 W	74.8 W	83 W	380 mA	94 %	0.97	-5 ... +50 °C	78 / 50 °C	28.70 k $\Omega$
	-	350 mA	70 V	228 V	25 W	80.0 W	89 W	410 mA	92 %	0.97	-5 ... +50 °C	78 / 50 °C	22.00 k $\Omega$
	-	375 mA	67 V	213 V	25 W	80.0 W	90 W	410 mA	92 %	0.97	-5 ... +50 °C	78 / 50 °C	17.80 k $\Omega$
	-	400 mA	62 V	200 V	25 W	80.0 W	90 W	410 mA	92 %	0.97	-5 ... +50 °C	78 / 50 °C	15.00 k $\Omega$
	-	425 mA	59 V	188 V	25 W	80.0 W	90 W	410 mA	92 %	0.97	-5 ... +50 °C	78 / 50 °C	12.10 k $\Omega$
	-	450 mA	56 V	177 V	25 W	80.0 W	90 W	410 mA	92 %	0.97	-5 ... +50 °C	78 / 50 °C	9.30 k $\Omega$
	-	475 mA	51 V	169 V	25 W	80.0 W	90 W	410 mA	92 %	0.97	-5 ... +50 °C	78 / 50 °C	6.49 k $\Omega$
	-	500 mA	50 V	160 V	25 W	80.0 W	90 W	410 mA	89 %	0.97	-5 ... +50 °C	78 / 50 °C	short circuit (0 $\Omega$ )
<b>CF operation</b>													
<b>EM powerLED BASIC FX 104 LP 80W 200V</b>	-	14 mA	-	-	2.4 W	3 W	8.5 W	85 mA	60 %	0.45	-	-	open
	-	17 mA	-	-	2.4 W	4 W	9.0 W	87 mA	67 %	0.50	-	-	64.90 k $\Omega$
	-	19 mA	-	-	2.4 W	4 W	9.0 W	87 mA	67 %	0.50	-	-	56.00 k $\Omega$
	-	23 mA	-	-	2.6 W	5 W	10.0 W	89 mA	71 %	0.50	-	-	48.70 k $\Omega$
	-	23 mA	-	-	2.3 W	5 W	10.0 W	89 mA	71 %	0.50	-	-	43.20 k $\Omega$
	-	28 mA	-	-	2.5 W	6 W	11.0 W	91 mA	75 %	0.55	-	-	36.50 k $\Omega$
	-	28 mA	-	-	2.3 W	6 W	11.0 W	92 mA	75 %	0.55	-	-	32.40 k $\Omega$
	-	32 mA	-	-	2.4 W	7 W	12.0 W	96 mA	78 %	0.60	-	-	28.70 k $\Omega$
	-	32 mA	-	-	2.2 W	7 W	12.0 W	96 mA	78 %	0.60	-	-	22.00 k $\Omega$
	-	36 mA	-	-	2.4 W	7 W	12.0 W	97 mA	74 %	0.60	-	-	17.80 k $\Omega$
	-	42 mA	-	-	2.6 W	7 W	13.0 W	98 mA	70 %	0.60	-	-	15.00 k $\Omega$
	-	42 mA	-	-	2.5 W	7 W	13.0 W	98 mA	70 %	0.60	-	-	12.10 k $\Omega$
	-	45 mA	-	-	2.5 W	7 W	13.0 W	98 mA	70 %	0.60	-	-	9.30 k $\Omega$
	-	46 mA	-	-	2.3 W	7 W	13.0 W	98 mA	70 %	0.60	-	-	6.49 k $\Omega$
	-	50 mA	-	-	2.5 W	7 W	13.0 W	98 mA	70 %	0.65	-	-	short circuit (0 $\Omega$ )
<b>Emergency operation</b>													
<b>EM powerLED BASIC</b>	4	see	50 V	200 V	3.00 W	3.85 W	-	-	-	-	-	-	-
<b>FX 104 LP 80W 200V</b>	5	page 7	50 V	200 V	3.80 W	4.90 W	-	-	-	-	-	-	-

<sup>①</sup> Efficiency without battery charging

<sup>②</sup> Ambient temperature range  $t_a$  defined in normal operation

<sup>③</sup> Output voltage range defined in normal operation. LED forward voltage will decrease in CF operation.

<sup>④</sup> EM = Emergency

RoHS

ACCES-  
SORIES

Test switch EM3

**Product description**

- For connection to the emergency lighting unit
- For checking the device function
- Plug connection



**Ordering data**

Type	Article number	Packaging, bag	Packaging, carton	Weight per pc.
Test switch EM 3	89899956	25 pc(s).	200 pc(s).	0.013 kg

ACCES-  
SORIES

Status indication green LED

**Product description**

- A green LED indicates that charging current is flowing into the battery



**Ordering data**

Type	Article number	Packaging, bag	Packaging, carton	Weight per pc.
LED EM green	89899605	25 pc(s).	200 pc(s).	0.011 kg
LED EM green, ultra high brightness	89899756	25 pc(s).	800 pc(s).	0.012 kg



ACCESSORIES

**smartSWITCH HF 5DP f**

Automatic switching based on motion and light level

**Product description**

- Motion detector for luminaire installation
- Motion detection through glass and thin materials (except metal)
- For automatic on/off switching of electronic ballasts
- Bright-out function: luminaire is not switched on if there is adequate brightness
- Delay time, detection range and light value for the bright-out function can be set via 9 dip switches
- Max. installation height 5 m
- Two housing options allowing flexible installation
- Variable detection area (100 – 10 %)
- Zero cross switching supported
- 5-year guarantee



smartSWITCH HF 5DP f



smartSWITCH HF 5DP S f

**Ordering data**

Type	Article number	Dimensions L x W x H	Packaging, carton	Weight per pc.
smartSWITCH HF 5DP f	28002214	70 x 36.5 x 24.5 mm	5 pc(s).	0.040 kg
smartSWITCH HF 5DP S f	28002235	58 x 48.5 x 24.5 mm	5 pc(s).	0.040 kg

## I-SELECT PLUG E

## Product description

- Ready-for-use resistor to set output current value
- Resistor is base isolated
- Resistor power 0.25 W
- Resistor value tolerance  $\pm 1\%$

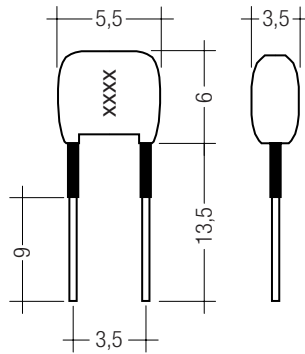

## Ordering data

Type	Article number	Colour	Marking	Resistor value	Output current	Packaging bag	Weight per pc.
I-SELECT PLUG E	28000628	Green	64k9	64.90 k $\Omega$	175 mA	10 pc(s).	0.001 kg
I-SELECT PLUG E	28000627	Green	56k	56.00 k $\Omega$	200 mA	10 pc(s).	0.001 kg
I-SELECT PLUG E	28000626	Green	48k7	48.70 k $\Omega$	225 mA	10 pc(s).	0.001 kg
I-SELECT PLUG E	28000625	Green	43k2	43.20 k $\Omega$	250 mA	10 pc(s).	0.001 kg
I-SELECT PLUG E	28000624	Green	36k5	36.50 k $\Omega$	275 mA	10 pc(s).	0.001 kg
I-SELECT PLUG E	28000623	Green	32k4	32.40 k $\Omega$	300 mA	10 pc(s).	0.001 kg
I-SELECT PLUG E	28000622	Green	28k7	28.70 k $\Omega$	325 mA	10 pc(s).	0.001 kg
I-SELECT PLUG E	28000621	Green	22k	22.00 k $\Omega$	350 mA	10 pc(s).	0.001 kg
I-SELECT PLUG E	28000620	Green	17k8	17.80 k $\Omega$	375 mA	10 pc(s).	0.001 kg
I-SELECT PLUG E	28000619	Green	15k	15.00 k $\Omega$	400 mA	10 pc(s).	0.001 kg
I-SELECT PLUG E	28000618	Green	12k1	12.10 k $\Omega$	425 mA	10 pc(s).	0.001 kg
I-SELECT PLUG E	28000617	Green	9k3	9.30 k $\Omega$	450 mA	10 pc(s).	0.001 kg
I-SELECT PLUG E	28000616	Green	6k49	6.49 k $\Omega$	475 mA	10 pc(s).	0.001 kg
I-SELECT PLUG E	28000612	Green	0R	0.00 k $\Omega$	500 mA	10 pc(s).	0.001 kg

## Battery selection

## EM powerLED BASIC FX 80 W, 1 / 3 h

		Type	EM powerLED BASIC FX 104 LP 80W 200V	EM powerLED BASIC FX 104 LP 80W 200V			
		Article no.	89800393	89800393			
		Cells	4 cells	5 cells			
		Output link	in	remove			
		Duration	1 h	3 h	1 h	3 h	
Technology and capacity	Design	Number of cells	Type	Article no.	Assignable batteries		
NiCd 1.6 Ah Cs cells	stick	1 x 4	Accu-NiCd C 4A	89899692	•		
	stick	1 x 5	Accu-NiCd C 5A	89899695		•	
	stick + stick	2 + 2	Accu-NiCd C 4C	89899694	•		
	stick + stick	2 + 3	Accu-NiCd C 5C	89899697		•	
	side by side	4 x 1	Accu-NiCd C 4B	89899693	•		
	side by side	5 x 1	Accu-NiCd C 5B	89899696		•	
NiCd 4 Ah D cells	stick	1 x 4	Accu-NiCd 4A 55	89800089		•	
	stick	1 x 5	Accu-NiCd 5A	89895973			•
	stick + stick	2 + 2	Accu-NiCd 4C	89895978		•	
	stick + stick	2 + 3	Accu-NiCd 5C 55	89800090			•
	side by side	4 x 1	Accu-NiCd 4B 55	89800385		•	
NiMH 2.2 Ah Cs cells	stick	1 x 4	Accu-NiMH 4A	28002089	•		
	stick	1 x 5	Accu-NiMH 5A	28002090		•	
	side by side	5 x 1	Accu-NiMH 5B	28002093		•	
NiMH 4 Ah LA cells	stick	1 x 4	Accu-NiMH 4Ah 4A CON	89800442		•	
	stick + stick	2 + 2	Accu-NiMH 4Ah 4C CON	89800438		•	
	stick + stick	2 + 3	Accu-NiMH 4Ah 5C CON	89800439			•

### Typ. LED current/voltage characteristics

The LED current in emergency mode is automatically adjusted by the EM powerLED module based on the total forward voltage of the LED modules connected and the associated battery.

EM powerLED BASIC FX 104 LP 80W 200V – 4 cells

Article number: 89800393

4.8 V battery voltage

750 – 960 mA battery discharge current (tolerance)

EM powerLED BASIC FX 104 LP 80W 200V – 5 cells

Article number: 89800393

6.0 V battery voltage

750 – 960 mA battery discharge current (tolerance)

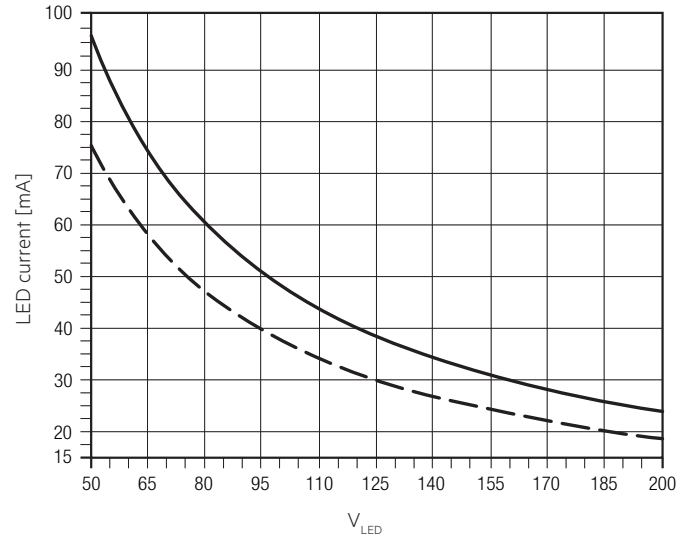
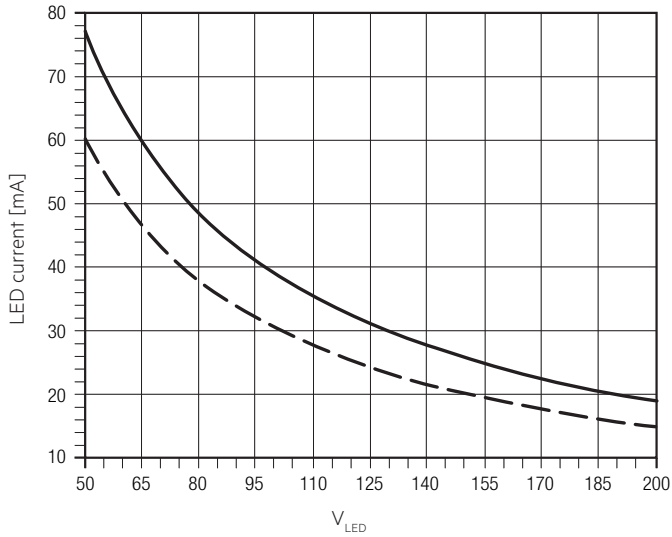

— — — — — LED current at nominal battery voltage and min. battery discharge current

————— LED current at nominal battery voltage and max. battery discharge current

#### LED peak current at start in emergency mode – 4 cells

Voltage	Inrush current	Duration
50 V	160 mA	20 ms
75 V	131 mA	10 ms
100 V	110 mA	8 ms
125 V	100 mA	6 ms
150 V	85 mA	4 ms
175 V	75 mA	3 ms
200 V	55 mA	3 ms

#### LED peak current at start in emergency mode – 5 cells

Voltage	Inrush current	Duration
50 V	175 mA	20 ms
75 V	140 mA	13 ms
100 V	125 mA	10 ms
125 V	110 mA	8 ms
150 V	100 mA	6 ms
175 V	90 mA	5 ms
200 V	75 mA	3 ms

Note: LED peak current is measured at the max. battery discharge current.



**Output current setting**

Output current can be set by connecting a resistor between the 2 "I set" terminals. Relationship between output current and resistor value can be found at the table "Specific technical data". Resistor values specified from standardised resistor value ranges.

Resistor value tolerance has to be  $\leq 1\%$ .

Resistor power has to be  $\geq 0.1$  W.

Resistor detection at each start.

Change of the resistor value during the operation will be not considered.

Resistors for the main output current values can be ordered from Tridonic (see accessories).

Note: The I SET terminals are rated as Non-SELV

**Overload protection**

LED Driver will switch off at overload operation. Mains reset is required to restart the LED Driver.

**Underload operation**

LED Driver will switch off at underload operation. Mains reset is required to restart the LED Driver.

**Short-circuit behaviour**

In case of a short circuit the unit switches to shut down mode. After elimination of the short circuit a mains reset (SL off/on) is necessary.

**Forward voltage out of range**

If the forward voltage is out of range the unit switches to shut down mode. After elimination of the short circuit a mains reset (SL off/on) is necessary.

**No-load operation or load loss during operation**

LED Driver will detect a load loss during operation. In this case and no-load operation the max. output voltage can apply at the LED output for max. 5 s before LED Driver shuts down. Mains reset is required to restart the LED Driver.

**Temperature range**

The LED Driver life duration is related to the ambient temperature  $t_a$ .

The relation of  $t_c$  to  $t_a$  temperature depends also on the luminaire design. If the measured  $t_c$  temperature is approx. 5 K below  $t_c$  max. or higher,  $t_a$  temperature should be checked and eventually critical components (e.g. ELCAP) measured.

Detailed information on request.

**Standards**

EN 55015

EN 61000-3-2

EN 61000-3-3

EN 61347-2-13

EN 61547

EN 62384

according to EN 60598-2-22

according to EN 50172

EN 61347-2-7

**Isolation and electric strength testing of luminaires**

Electronic LED Drivers can be damaged by high voltage. This has to be considered during the routine testing of the luminaires in production.

According to IEC 60598-1 Annex Q (informative only!) or ENEC 303-Annex A, each luminaire should be submitted to an isolation test with 500 V<sub>DC</sub> for 1 second. This test voltage should be connected between the interconnected phase and neutral terminals and the earth terminal. The isolation resistance must be at least 2 M $\Omega$ .

As an alternative, IEC 60598-1 Annex Q describes a test of the electrical strength with 1,500 V<sub>AC</sub> (or 1,414 x 1,500 V<sub>DC</sub>). To avoid damage to the electronic devices this test **must not be conducted**.

**Technical data batteries****Accu-NiCd****1.6 Ah**

Battery voltage/cell	1.2 V
Cell type	Cs
Case temperature range to ensure 4 years design life	+5 °C to +55 °C
Max. short term temperature (reduced life-time)	70 °C
Max. number discharge cycles	12 cycles per year plus 4 cycles during comissioning
Max. storage time	6 months

**4.2 / 4.5 Ah**

Battery voltage/cell	1.2 V
Cell type	D
Case temperature range to ensure 4 years design life	+5 °C to +55 °C
Max. short term temperature (reduced life-time)	70 °C
Max. number discharge cycles	12 cycles per year plus 4 cycles during comissioning
Max. storage time	6 months

**Accu-NiMh****2.2 Ah**

Battery voltage/cell	1.2 V
Cell type	Cs
Case temperature range to ensure 4 years design life	+5 °C to +50 °C
Max. short term temperature (reduced life-time)	70 °C
Max. number discharge cycles	4 cycles per year plus 30 cycles during comissioning
Max. storage time	6 months

**4.0 Ah**

Battery voltage/cell	1.2 V
Cell type	LA
Case temperature range to ensure 4 years design life	+5 °C to +45 °C
Max. short term temperature (reduced life-time)	70 °C
Max. number discharge cycles	4 cycles per year plus 30 cycles during comissioning
Max. storage time	6 months

**Batteries**

Connection method: 4.8x0.5 mm spade tag welded to end of cell

For stick packs this connection is accessible after the battery caps have been fitted.

To inhibit inverter operation disconnect the batteries by removing the connector from the battery spade tag.

For further information refer to corresponding battery datasheet.

**Storage, installation and commissioning**

Relevant information about storage conditions, installation and commissioning are provided in the battery datasheets.

**Mechanical details**

Channel manufactured from galvanised steel.

Cover manufactured from white pre-coated steel.

LED status indicator

- Green
- Mounting hole 6.5 mm dia
- Lead length 0.3 m / 1.0 m
- Insulation rating: 90 °C
- Plug connection

Test switch

- Mounting hole 7.0 mm dia
- Lead length 0.55 m
- Plug connection

Battery leads

- Quantity: 1 red and 1 black
- Length: 1.3 m
- Wire type: 0.5 mm<sup>2</sup> solid conductor
- Insulation rating: 90 °C

Battery end termination

Push on 4.8 mm receptacle to suit battery spade fitted with insulating cover

Module end termination

8.0 mm stripped insulation

Two-piece batteries are supplied with a 200 mm lead with 4.8 mm receptacle at each end and insulating covers to connect the separate sticks together.

**Electrical connections****Wiring**

LED module/LED Driver/supply

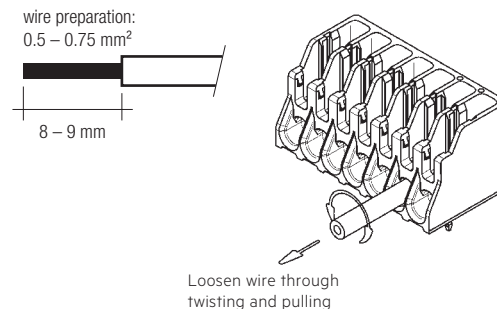
**IDC interface**

- solid wire with a cross section of 0.5 mm<sup>2</sup> according to the specification from IDC terminals

**Earth connection**

The earth connection is conducted as protection earth (PE). The LED Driver can be earthed via earth terminal or metal housing. If the LED Driver will be earthed, protection earth (PE) has to be used. There is no earth connection required for the functionality of the LED Driver.

Earth connection is recommended to improve following behaviour.

- Electromagnetic interferences (EMI)
- LED glowing at standby
- Transmission of mains transients to the LED output

In general it is recommended to earth the LED Driver if the LED module is mounted on earthed luminaire parts respectively heat sinks and thereby representing a high capacity against earth.

**Wiring type and cross section**

Solid wire with a cross section of 0.5 – 0.75 mm<sup>2</sup>. Strip 8 – 9 mm of insulation from the cables to ensure perfect operation of terminals.

**Installation instruction**

Max. torque for the mounting screws: 0.5 Nm / M4.

You must make sure that the LED is connected with the correct polarity. LEDs that are connected to EM powerLED should have polarity reversal protection such as a Schottky diode. There may be irreversible damage if the LED is connected with the wrong polarity. The protection device must be capable of handling a load of more than 700 mA.

**Life-time**

Average life-time 50,000 hours under rated conditions with a failure rate of less than 10%. Average failure rate of 0.2% per 1000 operating hours.

**Maximum lead length**

LED 3 m  
 Status indication LED 1 m  
 Batteries 1.3 m

**Storage conditions**

Humidity: 5% up to max. 85%,  
 not condensed  
 (max. 56 days/year at 85%)

Storage temperature: -40 °C up to max. +80 °C

The devices have to be within the specified temperature range (ta) before they are operated.

**Expected life-time**

Type	Output power	ta	40 °C	50 °C	55 °C
EM powerLED BASIC FX 104 LP 80W 200V	25 W	tc	57 °C	60 °C	72 °C
		life-time	> 100,000 h	> 100,000 h	85,000 h
	45 W	tc	61 °C	71 °C	71 °C
		life-time	> 100,000 h	75,000 h	55,000 h
	65 W	tc	63 °C	70 °C	73 °C
		life-time	> 100,000 h	70,000 h	70,000 h
	80 W	tc	67 °C	70 °C	x
		life-time	> 100,000 h	50,000 h	x

x = not permitted



**Maximum loading of automatic circuit breakers**

Automatic circuit breaker type	C10	C13	C16	C20	B10	B13	B16	B20	Inrush current
Installation Ø	1.5 mm <sup>2</sup>	1.5 mm <sup>2</sup>	2.5 mm <sup>2</sup>	2.5 mm <sup>2</sup>	1.5 mm <sup>2</sup>	1.5 mm <sup>2</sup>	2.5 mm <sup>2</sup>	2.5 mm <sup>2</sup>	I <sub>max</sub> time
EM powerLED BASIC FX 104 LP 80W 200V	12	18	24	28	6	9	12	14	32.6 A 260 µs



**Harmonic distortion in the mains supply (at 230 V / 50 Hz and full load) in %**

Type	THD	3	5	7
EM powerLED BASIC FX 104 LP 80W 200V	10 %	8 %	3 %	3 %

**Duration link selection**

Duration	Usage duration link
3 h	 With link
1 h	 Without link

**Standard/High output selection**

Output	Usage link
Standard output 4 cells	 With link
High output 5 cells	 Without link

Note: LED Driver supplied with duration link in 3 hours position and standard/high output link in standard output position. Remove duration link for 1 hour duration. Remove standard/high output link for high output configuration. Duration link and standard/high output link must be set before battery and mains connection.

### Wiring guidelines

- The output to the LED is DC but has high frequency content, which should be considered for good EMC compliance.
- LED leads should be separated from the mains connections and wiring for good EMC performance.
- Maximum lead length on the LED terminals is 3 m. For a good EMC performance keep the LED wiring as short as possible.
- Maximum lead length for the Test switch and Indicator LED connection is 1 m. The test switch and Indicator LED wiring should be separated from the LED leads to prevent noise coupling.
- Battery leads are specified with 0.5 mm cross section and a length of 1.3 m.
- To avoid the damage of the control gear, the wiring must be protected against short circuits to earth (sharp edged metal parts, metal cable clips, louver, etc.).

To ensure that a luminaire containing LED emergency units complies with EN 55015 for radio frequency conducted interference in both normal and emergency mode it is essential to follow good practice in the wiring layout.

Within the luminaire the switched and unswitched 50 Hz supply wiring must be routed as short as possible and be kept as far away as possible from the LED leads. Through wiring may affect the emc performance of the luminaire.

The length of LED leads must not be exceeded.

The output current depends on the forward voltage and the tolerance of the LED modules.

### Wiring diagram EM powerLED BASIC FX 80 W without sensor

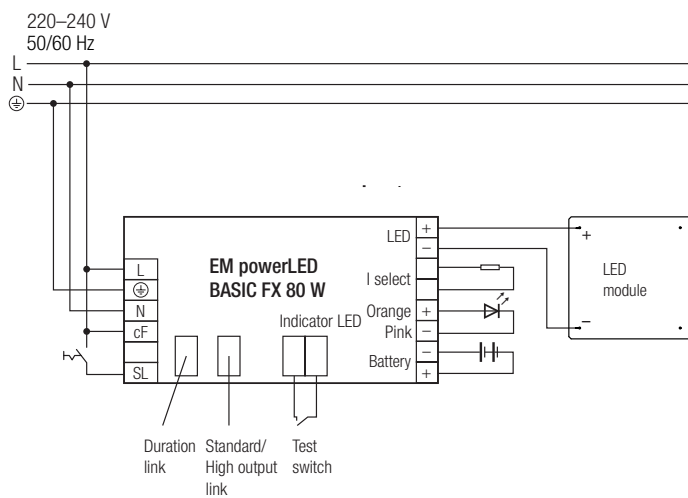

The connected LED module will be used for mains and emergency operation.

### Wiring diagram EM powerLED BASIC FX 80 W with sensor

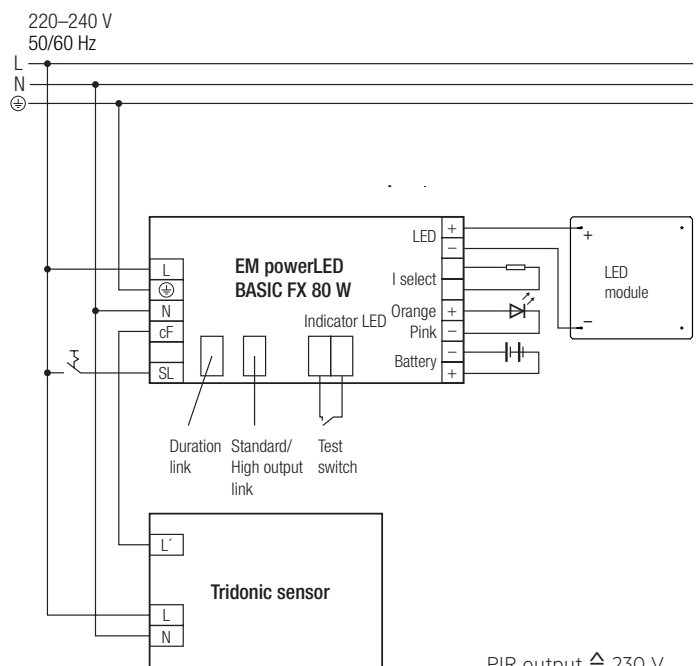

PIR output  $\hat{=}$  230 V

### Switching behaviour

SL	CF	LED
off	off	off
off	on	off
on	off	10 %
on	on	100 %

The mains power must be removed before changing the LED load.

Secondary switching of LEDs is not allowed and may cause damage to the LEDs. The hot plug-in of LEDs during normal operation may result in high current peaks.

### Note

The EM powerLED BASIC FX 80W uses pulse width modulation (PWM) for the LED operation in CORRIDOR mode. This can have an adverse effect on video recording equipment e.g. cctv. Caution should be observed when using the CORRIDOR FUNCTION in cctv monitored areas.

### Additional information

Additional technical information at [www.tridonic.com](http://www.tridonic.com) → Technical Data

Guarantee conditions at [www.tridonic.com](http://www.tridonic.com) → Services

Life-time declarations are informative and represent no warranty claim. No warranty if device was opened.