



Driver LC 60W 900–1750mA flexC SR EXC

EXCITE series

Product description

- Constant current LED Driver
- Dimmable via ready2mains™ Gateway
- Dimming range 15 – 100 % (Depending on load.
For details refer to chapter 4.7 Dimming in data sheet.)
- Adjustable output current between 900 and 1,750 mA
via ready2mains™ Programmer or I-select 2 plugs
- Max. output power 60 W
- Up to 90 % efficiency
- Nominal life-time up to 100,000 h
- 5-year guarantee



Housing properties

- Casing: polycarbonate, white
- Type of protection IP20
- Strain relief with loop through function

Interfaces

- ready2mains™ (configuration and dimming via mains)
- Terminal blocks: 45° / 0° push terminals

Functions

- Adjustable output current in 1-mA-steps (ready2mains™, I-select 2)
- Dimmable via ready2mains™ interface
- Protective features (overtemperature, short-circuit, overload, no-load, input voltage range)
- Suitable for emergency escape lighting systems acc. to EN 50172
- For cable cross-sections up to 2.5 mm²

Benefits

- Application-oriented operating window for maximum compatibility
- Best energy savings due to high efficiency and dimming via ready2mains™
- Flexible configuration via ready2mains™ and I-select 2
- Reliability proven by life-time up to 100,000 h and 5-year guarantee
- No tools required for installation

Typical applications

- For downlight, spotlight and decorative applications



Standards, page 4

IP20 SELV

Driver LC 60W 900-1750mA flexC SR EXC

EXCITE series

Technical data

Rated supply voltage	220 – 240 V
AC voltage range	198 – 264 V
DC voltage range	176 – 280 V
Mains frequency	0 / 50 / 60 Hz
Overvoltage protection	320 V AC, 48 h
Typ. current (at 230 V, 50 Hz, full load) ^① [Ⓜ]	306 mA
Typ. current (220 V, 0 Hz, full load, 50 % dimming level) [Ⓜ] 137 mA	
Leakage current (at 230 V, 50 Hz, full load) ^① [Ⓜ]	< 250 µA
Max. input power	67 W
Typ. efficiency (at 230 V / 50 Hz / full load) [Ⓜ]	90 %
λ (at 230 V, 50 Hz, full load) ^①	0.95
Typ. input current in no-load operation	19.5 mA
Typ. input power in no-load operation	0.08 W
In-rush current (peak / duration)	25.9 A / 252 µs
THD (at 230 V, 50 Hz, full load) ^①	< 7 %
Time to light (at 230 V, 50 Hz, full load) ^①	< 500 ms
Time to light (DC mode)	< 500 ms
Switchover time (AC/DC)	< 0.2 s
Turn off time (at 230 V, 50 Hz, full load)	< 50 ms
Output current tolerance ^③ [Ⓜ]	± 5 %
Max. output current peak (non-repetitive)	≤ output current + 35 %
Output LF current ripple (< 120 Hz)	± 5 %
Max. output voltage (no-load voltage)	60 V
Dimming range [Ⓜ]	15 – 100 %
Mains surge capability (between L - N)	1 kV
Mains surge capability (between L/N - PE)	2 kV
Surge voltage at output side (against PE)	< 500 V
Dimensions L x W x H	220 x 85 x 31 mm

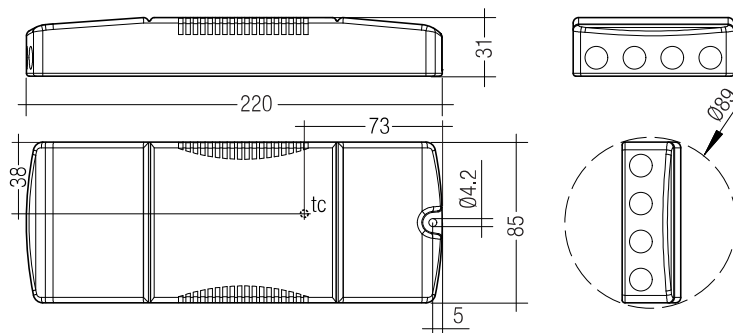

Ordering data

Type	Article number	Packaging carton	Packaging pallet	Weight per pc.
LC 60W 900-1750mA flexC SR EXC	28000702	10 pc(s).	400 pc(s).	0.278 kg

Specific technical data

Type	Output current ^④ [Ⓜ]	Min. forward voltage	Max. forward voltage	Max. output power	Typ. power consumption (at 230 V, 50 Hz, full load)	Typ. current consumption (at 230 V, 50 Hz, full load)	Max. casing temperature t _c	Ambient temperature t _a max.	I-select 2 resistor value ^⑤
LC 60W 900-1750mA flexC SR EXC	900 mA	20 V	54.0 V	48.6 W	53.8 W	241 mA	75 °C	-25 ... +50 °C	open
	950 mA	20 V	54.0 V	51.3 W	57.0 W	255 mA	75 °C	-25 ... +50 °C	5.26 kΩ
	1,000 mA	20 V	54.0 V	54.0 W	59.5 W	265 mA	75 °C	-25 ... +50 °C	5.00 kΩ
	1,050 mA	20 V	54.0 V	56.7 W	62.8 W	279 mA	75 °C	-25 ... +50 °C	4.76 kΩ
	1,100 mA	20 V	54.0 V	59.4 W	64.7 W	291 mA	75 °C	-25 ... +50 °C	4.55 kΩ
	1,150 mA	20 V	52.2 V	60.0 W	65.5 W	294 mA	70 °C	-25 ... +50 °C	4.35 kΩ
	1,200 mA	20 V	50.0 V	60.0 W	65.7 W	292 mA	70 °C	-25 ... +50 °C	4.17 kΩ
	1,250 mA	20 V	48.0 V	60.0 W	66.7 W	306 mA	70 °C	-25 ... +50 °C	4.00 kΩ
	1,300 mA	20 V	46.2 V	60.0 W	66.4 W	295 mA	70 °C	-25 ... +50 °C	3.85 kΩ
	1,350 mA	20 V	44.4 V	60.0 W	66.1 W	303 mA	70 °C	-25 ... +50 °C	3.70 kΩ
	1,400 mA	20 V	42.9 V	60.0 W	66.1 W	294 mA	70 °C	-25 ... +50 °C	3.57 kΩ
	1,450 mA	20 V	41.4 V	60.0 W	66.6 W	306 mA	70 °C	-25 ... +50 °C	3.45 kΩ
	1,500 mA	20 V	40.0 V	60.0 W	66.8 W	296 mA	70 °C	-25 ... +50 °C	3.33 kΩ
	1,550 mA	20 V	38.7 V	60.0 W	66.7 W	298 mA	70 °C	-25 ... +50 °C	3.23 kΩ
	1,600 mA	20 V	37.5 V	60.0 W	66.4 W	295 mA	70 °C	-25 ... +50 °C	3.13 kΩ
	1,650 mA	20 V	37.5 V	60.0 W	66.0 W	303 mA	70 °C	-25 ... +50 °C	3.03 kΩ
	1,700 mA	20 V	35.3 V	60.0 W	66.8 W	297 mA	70 °C	-25 ... +50 °C	2.94 kΩ
1,750 mA	20 V	34.3 V	60.0 W	66.8 W	297 mA	70 °C	-25 ... +50 °C	short circuit (0 Ω)	

^① Valid at 100 % dimming level.

^② Depending on the selected output current.

^③ The min. achievable dimming level depends on the connected load. For details refer to chapter 4.7 Dimming in data sheet.

^④ The table only lists a number of possible operating points but does not cover each single point. The output current can be set within the total value range in 1-mA-steps.

^⑤ Not compatible with I-select (generation 1).

[Ⓜ] Output current is mean value.

Product description

- Ready-for-use resistor to set output current value
- Compatible with LED Driver featuring I-select 2 interface; not compatible with I-select (generation 1)
- Resistor is base isolated
- Resistor power 0.25 W
- Current tolerance $\pm 2\%$ additional to output current tolerance
- Compatible with LED Driver series PRE and EXC

Example of calculation

- $R [k\Omega] = 5 V / I_{out} [mA] \times 1000$
- Resistor value tolerance $\leq 1\%$; resistor power $\geq 0.1 W$; base isolation necessary
- When using a resistor value beyond the specified range, the output current will automatically be set to the minimum value (resistor value too big), respectively to the maximum value (resistor value too small)

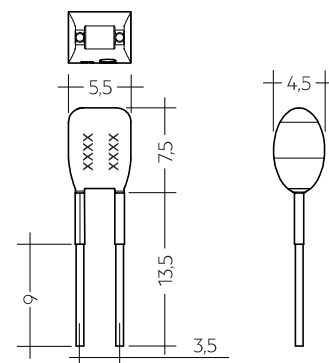

Ordering data

Type	Article number	Colour	Marking	Current	Packaging bag	Weight per pc.
I-SELECT 2 PLUG 900MA BL	28001122	Blue	0900 mA	900 mA	10 pc(s).	0.001 kg
I-SELECT 2 PLUG 950MA BL	28001123	Blue	0950 mA	950 mA	10 pc(s).	0.001 kg
I-SELECT 2 PLUG 1000MA BL	28001124	Blue	1000 mA	1,000 mA	10 pc(s).	0.001 kg
I-SELECT 2 PLUG 1050MA BL	28001125	Blue	1050 mA	1,050 mA	10 pc(s).	0.001 kg
I-SELECT 2 PLUG 1100MA BL	28001126	Blue	1100 mA	1,100 mA	10 pc(s).	0.001 kg
I-SELECT 2 PLUG 1150MA BL	28001127	Blue	1150 mA	1,150 mA	10 pc(s).	0.001 kg
I-SELECT 2 PLUG 1200MA BL	28001128	Blue	1200 mA	1,200 mA	10 pc(s).	0.001 kg
I-SELECT 2 PLUG 1250MA BL	28001129	Blue	1250 mA	1,250 mA	10 pc(s).	0.001 kg
I-SELECT 2 PLUG 1300MA BL	28001130	Blue	1300 mA	1,300 mA	10 pc(s).	0.001 kg
I-SELECT 2 PLUG 1350MA BL	28001131	Blue	1350 mA	1,350 mA	10 pc(s).	0.001 kg
I-SELECT 2 PLUG 1400MA BL	28001132	Blue	1400 mA	1,400 mA	10 pc(s).	0.001 kg
I-SELECT 2 PLUG 1500MA BL	28001133	Blau	1500 mA	1,500 mA	10 pc(s).	0.001 kg
I-SELECT 2 PLUG 1600MA BL	28001134	Blau	1600 mA	1,600 mA	10 pc(s).	0.001 kg
I-SELECT 2 PLUG 1700MA BL	28001135	Blau	1700 mA	1,700 mA	10 pc(s).	0.001 kg
I-SELECT 2 PLUG MAX BL	28001099	Blue	MAX	MAX	10 pc(s).	0.001 kg

1. Standards

EN 55015
EN 61000-3-2
EN 61000-3-3
EN 61347-1
EN 61347-2-13
EN 62384
EN 61547

According to EN 50172 for use in central battery systems
According to EN 60598-2-22 suitable for emergency lighting installations

2. Thermal details and life-time

2.1 Expected life-time

Expected life-time				
Type	Output current	ta	40 °C	50 °C
LC 60W 900-1750mA flexC SR EXC	900 – 1,100 mA	tc	65 °C	75 °C
		Life-time	> 100,000 h	> 100,000 h
	> 1,100 mA	tc	60 °C	70 °C
		Life-time	> 100,000 h	> 100,000 h

The LED Driver is designed for a life-time stated above under reference conditions and with a failure probability of less than 10 %.

The relation of tc to ta temperature depends also on the luminaire design.

If the measured tc temperature is approx. 5 K below tc max., ta temperature should be checked and eventually critical components (e.g. ELCAP) measured. Detailed information on request.

3. Installation / wiring

3.1 Circuit diagram

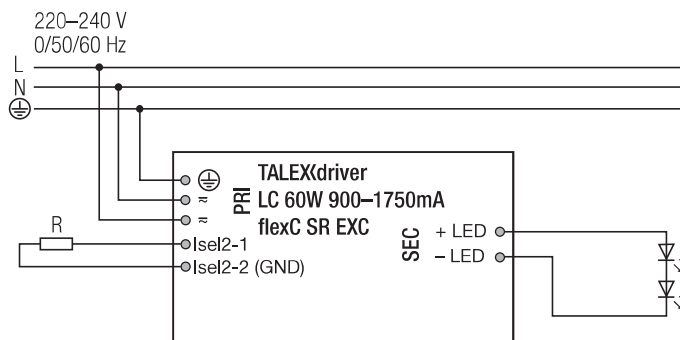

For wiring in dimming operation refer to the ready2mains Gateway data sheet.

3.2 Wiring type and cross section

Mains supply wires

Stranded wire or solid wire from 0.5 to 2.5 mm² may be used for wiring. Strip 10–11 mm of insulation from the cables to ensure perfect operation of the push terminals.

Use one wire for each terminal connector only.
Use each strain relief channel for one cable only.

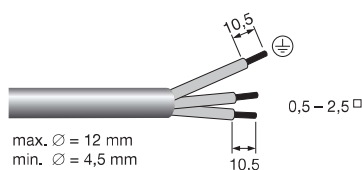

1.1 Glow wire test

according to EN 61347-1 with increased temperature of 850 °C passed.

Secondary wires (LED module)

The wiring can be in stranded wires with ferrules or solid with a cross section of 0.2–1.5 mm².

Strip 8.5–9.5 mm of insulation from the cables to ensure perfect operation of the push-wire terminals.

Use one wire for each terminal connector only.

Use each strain relief channel for one cable only.

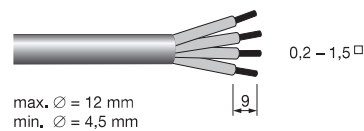

3.3 Loose wiring

Press down the “push button” and remove the cable from front.

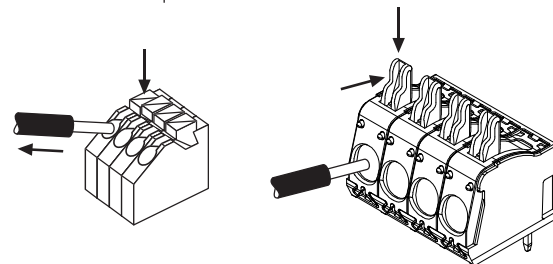

3.4 Fixing conditions

Dry, acidfree, oilfree, fatfree. It is not allowed to exceed the maximum ambient temperature (ta) stated on the device. Minimum distances stated below are recommendations and depend on the actual luminaire.

Is not suitable for fixing in corner.

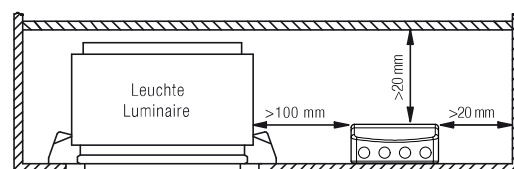

3.5 Wiring guidelines

- The cables should be run separately from the mains connections and mains cables to ensure good EMC conditions.
- The LED wiring should be kept as short as possible to ensure good EMC. The max. secondary cable length is 2 m (4 m circuit).
- Secondary switching is not permitted.
- The LED Driver has no inverse-polarity protection on the secondary side. Wrong polarity can damage LED modules with no inverse-polarity protection.
- Wrong wiring of the LED Driver can lead to malfunction or irreparable damage.
- Through wiring of mains is for connecting additional LED Driver only. Max. permanent current of 16 A may not be exceeded.

3.6 Hot plug-in

Hot plug-in is not supported due to residual output voltage of > 0 V. If a LED load is connected, the device has to be restarted before the output will be activated again. This can be done via mains reset or via interface ready2mains.

3.7 Earth connection

The earth connection is conducted as protection earth (PE). If the LED Driver will be earthed, protection earth (PE) has to be used. There is no earth connection required for the functionality of the LED Driver. Earth connection is recommended to improve following behaviour:

- Electromagnetic interferences (EMI)
- Transmission of mains transients to the LED output

In general it is recommended to earth the LED Driver if the LED module is mounted on earthed luminaire parts respectively heat sinks and thereby representing a high capacity against earth.

3.8 I-select 2 resistors connected via cable

For details see:
http://www.tridonic.com/com/en/download/technical/LCA_PRE_LC_EXC_ProductManual_en.pdf.

4. Electrical values

4.1 Operating window

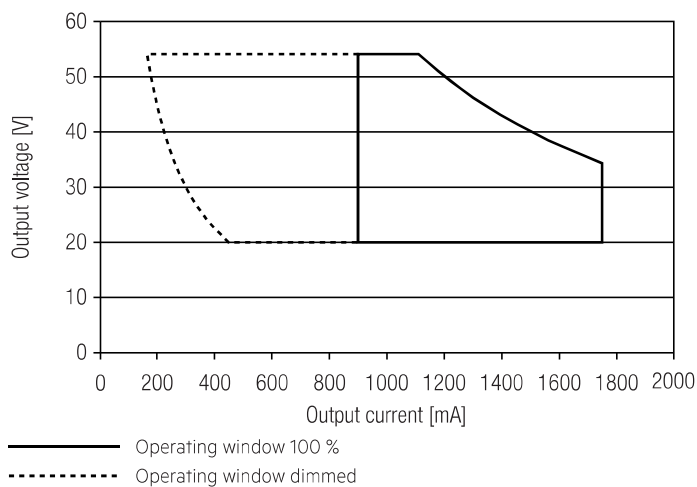

— Operating window 100 %
- - - Operating window dimmed

Make sure that the LED Driver is operated within the given window under all operating conditions. Special attention needs to be paid at dimming and DC emergency operation as the forward voltage of the connected LED modules varies with the dimming level, due to the implemented amplitude dimming technology. Coming below the specified minimum output voltage of the LED Driver may cause the device to shut-down. See chapter "6.8 DC emergency operation" for more information.

4.2 Efficiency vs load

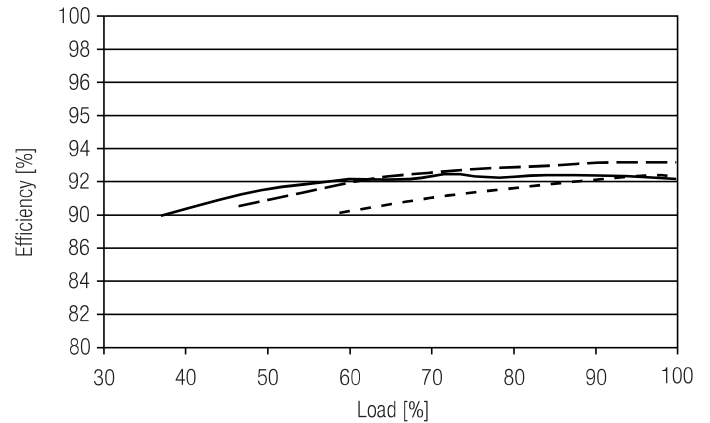

4.3 Power factor vs load

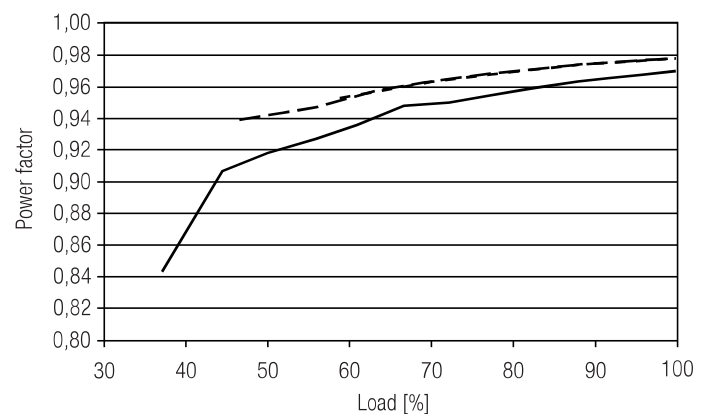

4.4 THD vs load

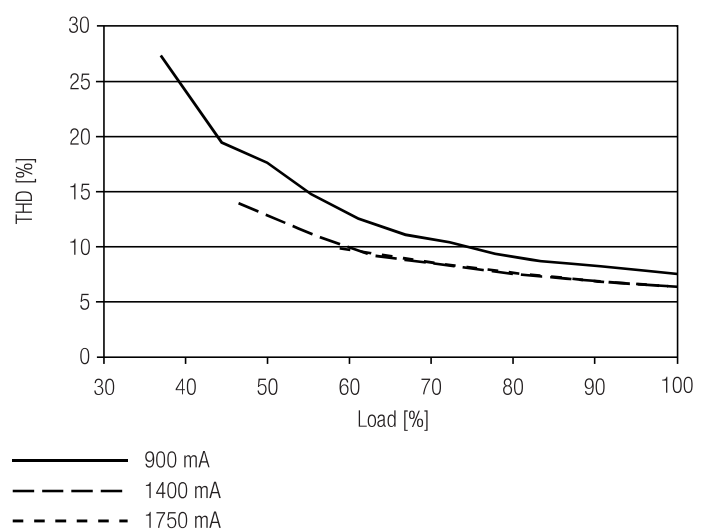

— 900 mA
- - - 1400 mA
- . - . 1750 mA

100 % load corresponds to the max. output power (full load) according to the table on page 2.

4.5 Maximum loading of automatic circuit breakers

Automatic circuit breaker type	C10	C13	C16	C20	B10	B13	B16	B20	Inrush current	
Installation \varnothing	1.5 mm ²	1.5 mm ²	2.5 mm ²	2.5 mm ²	1.5 mm ²	1.5 mm ²	2.5 mm ²	2.5 mm ²	I_{max}	time
LC 60W 900-1750mA flexC SR EXC	18	23	30	36	11	14	18	22	25.9 A	252 μ s

Calculation uses typical values from ABB series S200 as a reference.
Actual values may differ due to used circuit breaker types and installation environment.

4.6 Harmonic distortion in the mains supply (at 230 V / 50 Hz and full load) in %

	THD	3.	5.	7.	9.	11.
LC 60W 900-1750mA flexC SR EXC	< 6	< 4	< 2	< 2	< 2	< 2

4.7 Dimming

Dimming range 15 to 100%.
The minimum achievable dimming level depends on the connected load.
The operating window shows the minimum reachable power in dimmed state.
The output power at minimum dimming level is 15 % of absolute the max. output power of the LED Driver for all loads within the entire operating window.
For loads below the max. output power, the minimum dimming level is higher.
To determine the minimum dimming level for a certain load carefully read the operating window.
For further information please refer to your Tridonic sales contact.

5. Interfaces / communication

5.1 Control input ready2mains (L, N)

The digital ready2mains protocol is modulated onto the mains signal which is wired to the mains terminal (L and N).

6. Functions

6.1 Function: adjustable current

The output current of the LED Driver can be adjusted in a certain range. For adjustment there are two options available.

Option 1: I-select 2

By inserting a suitable resistor or third party resistor into the I-select 2 interface, the current value can be adjusted. The relationship between output current and resistor value can be found in the chapter "Accessories I-SELECT 2 Plugs".



Please note that the resistor values for I-select 2 are not compatible with I-select (generation 1). Installation of an incorrect resistor may cause irreparable damage to the LED module(s).

Resistors for the main output current values can be ordered from Tridonic (see accessories).

Option 2: ready2mains

Adjustment is done by the ready2mains Programmer and the corresponding configuration software (see ready2mains documentation).



Current adjustment can only be done five times over ready2mains. To program the LED Driver a connected load is necessary that is within the operating window of the LED Driver.

The priority for current adjustment methods is I-select 2 followed by ready2mains (lowest priority).

6.2 ready2mains – configuration

The ready2mains interface enables the configuration of the mostly used parameters via the mains wiring. In the case of EXC LED Driver, it is the LED output current as well as an optional lockbit to prevent any accidental configuration at a later stage.

The configuration is done via the ready2mains Programmer, either directly at the Programmer itself or via a respective software tool. For details on the configuration via ready2mains see the technical information of the Programmer and its tools.

6.3 ready2mains – dimming

The ready2mains interface also allows for mains-based group dimming, without the need for dedicated control wires. The dimming commands from the control unit are transferred into the digital ready2mains protocol by a ready2mains Gateway. This device then broadcasts the dimming signal to all connected LED drivers via the mains wiring. For details on the dimming functionality via ready2mains see the technical information to ready2mains as well as to the Gateways.

6.4 Short-circuit behaviour

In case of a short-circuit at the LED output the LED output is switched off. After restart of the LED Driver the output will be activated again. The restart can either be done via mains reset or via interface ready2mains.

6.5 No-load operation

The LED Driver will not be damaged in no-load operation. The output will be deactivated and is therefore free of voltage. If a LED load is connected the device has to be restarted before the output will be activated again.

6.6 Overload protection

If the output voltage range is exceeded the LED Driver turns off the LED output. After restart of the LED Driver the output will be activated again. The restart can either be done via mains reset or via interface ready2mains.

6.7 Overtemperature protection

The LED Driver is protected against temporary thermal overheating. If the temperature limit is exceeded the output current of the LED module(s) is reduced. The temperature protection is activated approx. +5 °C above $t_{c\ max}$ (see page 2). On DC operation this function is deactivated to fulfill emergency requirements.

6.8 DC emergency operation

The LED Driver is designed to operate on DC voltage and pulsed DC voltage. For a reliable operation, make sure that also in DC emergency operation the LED Driver is run within the specified conditions as stated in chapter "4.1 Operating window".

Light output level in DC operation (EOF_i): 50 % (cannot be adjusted)

The voltage-dependent input current of Driver incl. LED module is depending on the used load.

The nominal voltage-dependent no-load current of Driver (without or defect LED module) is for:

AC: < 21.4 mA (at 230 V, 50 Hz)

DC: < 5 mA (at 275 – 186 V, 0 Hz)

7. Miscellaneous

7.1 Isolation and electric strength testing of luminaires

Electronic devices can be damaged by high voltage. This has to be considered during the routine testing of the luminaires in production.

According to IEC 60598-1 Annex Q (informative only!) or ENEC 303-Annex A, each luminaire should be submitted to an isolation test with 500 V_{DC} for one second. This test voltage should be connected between the interconnected phase and neutral terminals and the earth terminal. The isolation resistance must be at least 2 MΩ.

As an alternative, IEC 60598-1 Annex Q describes a test of the electrical strength with 1500 V_{AC} (or 1.414 x 1500 V_{DC}). To avoid damage to the electronic devices this test must not be conducted.

7.2 Conditions of use and storage

Environmental conditions: 5 % up to max. 85 %,
not condensed
(max. 56 days/year at 85 %)

Storage temperature: -40 °C up to max. +80 °C

The devices have to be acclimatised to the specified temperature range (t_a) before they can be operated.

7.3 Additional information

Additional technical information at www.tridonic.com → Technical Data

Guarantee conditions at www.tridonic.com → Services

Life-time declarations are informative and represent no warranty claim. No warranty if device was opened.