

NiCd Accus 1.6 – 4.5 Ah

Nickel-cadmium cells (NiCd)

Product description

- High-temperature NiCd cells for use with emergency lighting units
- 4-year design life
- 1-year guarantee

Properties

- Constant high-temperature operation – depending on the emergency lighting unit used (refer to respective emergency control gear data sheet)
- Good charging properties at high temperature
- High energy maintenance of the charged battery
- Certified quality manufacturer
- In various configurations
- Simple connection with blade terminal respectively plug terminal
- With polycarbonate fixing caps and connecting cable
- Electrical connection with mounted end caps possible
- Suitable for emergency lighting equipment as per IEC 60598-2-22



Standards, page 4



Fig. 1: Stick
Connection: blade terminal



Fig. 2: Stick + Stick
Connection: blade terminal



Fig. 3: Side by side
Connection: blade terminal



Fig. 4: Side by side
Connection: plug terminal

NiCd Accus 1.6 – 4.5 Ah

Nickel-cadmium cells (NiCd)

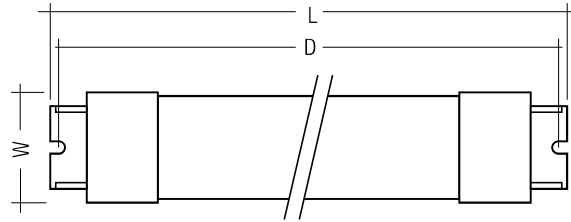

Fig. 1: Stick
Connection: blade terminal

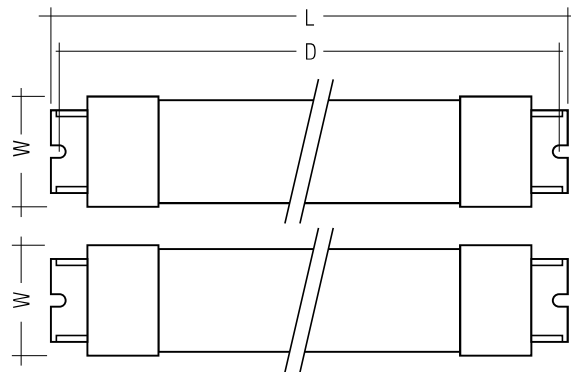

Fig. 2: Stick + Stick
Connection: blade terminal

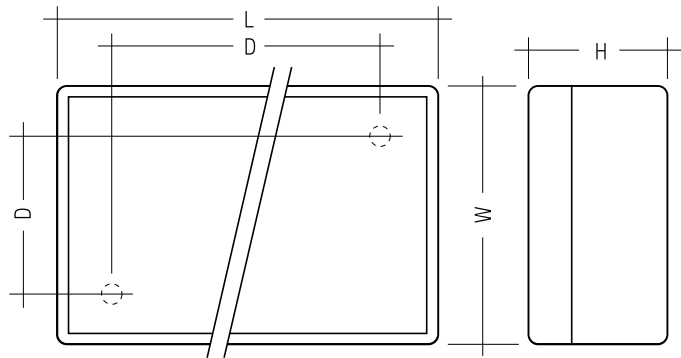

Fig. 3: Side by side
Connection: blade terminal

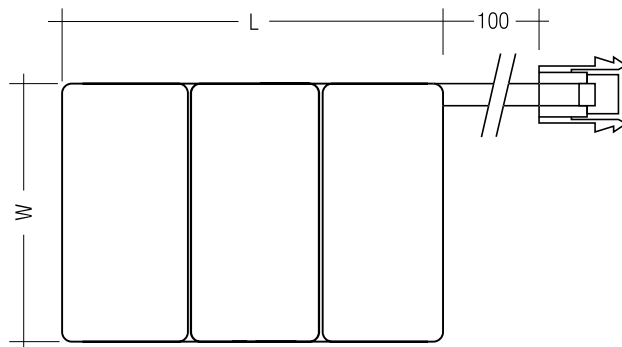

Fig. 4: Side by side
Connection: plug terminal

Technical data

Battery voltage per cell	1.2 V
Min. battery casing temp. (design life of 4 years)	+5 °C
Max. battery casing temp. (design life of 4 years)	refer to emergency control gear datasheet

Ordering data

Type	Article number [®]	Packaging, carton	Packaging, outer box	Weight per pc.
NiCd D cells – stick				
Accu-NiCd 2A 55	89800092	5 pc(s).	25 pc(s).	0.225 kg
Accu-NiCd 3A	89895960	5 pc(s).	25 pc(s).	0.386 kg
Accu-NiCd 4A 55	89800089	5 pc(s).	25 pc(s).	0.500 kg
Accu-NiCd 5A	89895973	5 pc(s).	25 pc(s).	0.640 kg
NiCd D cells – stick + stick				
Accu-NiCd 4C	89895978	5 pc(s).	25 pc(s).	0.530 kg
Accu-NiCd 5C 55	89800090	5 pc(s).	25 pc(s).	0.620 kg
Accu-NiCd 6C 55	89800388	5 pc(s).	25 pc(s).	0.756 kg
NiCd D cells – side by side				
Accu-NiCd 3B 55	89800384	5 pc(s).	25 pc(s).	0.380 kg
Accu-NiCd 4B 55	89800385	5 pc(s).	25 pc(s).	0.460 kg
NiCd Cs cells – stick				
Accu-NiCd C 3A	89899743	5 pc(s).	25 pc(s).	0.190 kg
Accu-NiCd C 4A	89899692	5 pc(s).	25 pc(s).	0.220 kg
Accu-NiCd C 5A	89899695	5 pc(s).	25 pc(s).	0.249 kg
Accu-NiCd C 6A	89899698	5 pc(s).	25 pc(s).	0.296 kg
NiCd Cs cells – stick + stick				
Accu-NiCd C 4C	89899694	5 pc(s).	25 pc(s).	0.198 kg
Accu-NiCd C 5C	89899697	5 pc(s).	25 pc(s).	0.225 kg
Accu-NiCd C 6C	89899699	5 pc(s).	25 pc(s).	0.270 kg
NiCd Cs cells – side by side				
Accu-NiCd C 4B	89899693	5 pc(s).	25 pc(s).	0.180 kg
Accu-NiCd C 5B	89899696	5 pc(s).	25 pc(s).	0.249 kg

Specific technical data

Type	Article number [®]	Image	Number of cells	Capacity	Length L	Hole spacing D	Width B	Height H
NiCd D cells – stick								
Accu-NiCd 2A 55	89800092	1	2	4.5 Ah	152 mm	140 mm	36 mm	35 mm
Accu-NiCd 3A	89895960	1	3	4.2 Ah	210 mm	198 mm	36 mm	35 mm
Accu-NiCd 4A 55	89800089	1	4	4.5 Ah	269 mm	257 mm	36 mm	35 mm
Accu-NiCd 5A	89895973	1	5	4.2 Ah	328 mm	316 mm	36 mm	35 mm
NiCd D cells – stick + stick								
Accu-NiCd 4C	89895978	2	4	4.2 Ah	152 mm	140 mm	36 mm	35 mm
Accu-NiCd 5C 55	89800090	2	5	4.5 Ah	151 + 210 mm	140 + 198 mm	36 mm	35 mm
Accu-NiCd 6C 55	89800388	2	6	4.5 Ah	210 mm	198 mm	36 mm	35 mm
NiCd D cells – side by side								
Accu-NiCd 3B 55	89800384	4	3	4.5 Ah	63 mm	32 x 40 mm	98 mm	35 mm
Accu-NiCd 4B 55	89800385	4	4	4.5 Ah	63 mm	64 x 40 mm	131 mm	35 mm
NiCd Cs cells – stick								
Accu-NiCd C 3A	89899743	1	3	1.6 Ah	164 mm	152 mm	26 mm	26 mm
Accu-NiCd C 4A	89899692	1	4	1.6 Ah	206 mm	194 mm	26 mm	26 mm
Accu-NiCd C 5A	89899695	1	5	1.6 Ah	249 mm	237 mm	26 mm	26 mm
Accu-NiCd C 6A	89899698	1	6	1.6 Ah	292 mm	280 mm	26 mm	26 mm
NiCd Cs cells – stick + stick								
Accu-NiCd C 4C	89899694	2	4	1.6 Ah	121 mm	109 mm	26 mm	26 mm
Accu-NiCd C 5C	89899697	2	5	1.6 Ah	164 + 121 mm	152 + 109 mm	26 mm	26 mm
Accu-NiCd C 6C	89899699	2	6	1.6 Ah	164 mm	152 mm	26 mm	26 mm
NiCd Cs cells – side by side								
Accu-NiCd C 4B	89899693	3	4	1.6 Ah	148 mm	40 x 96 mm	54 mm	25 mm
Accu-NiCd C 5B	89899696	3	5	1.6 Ah	148 mm	40 x 96 mm	54 mm	25 mm

[®]Art.no. 89895960, 89895963, 89895973, 89895978 on request.

1. Standards

The battery cells are designed to comply with the IEC international standard and tested according to the normative permanent charge endurance test described in the IEC 61951-1 standard. This performance is mandatory for use in Emergency Lighting Units to comply with the IEC 60598 2.22.

1.1 Glow-wire test

according to EN 61347-1 with increased temperature of 960 °C passed.

2. Thermal data

2.1 Storage conditions

- Store batteries within the specified temperature range in low humidity conditions. Optimal storage conditions are:
 - temperature: +5... +25 °C
 - relative humidity: 65 % ±5 %
- Avoid atmosphere with corrosive gas
- Disconnect batteries before store or delivery
- Avoid storage of discharged batteries
- Maximum storage time without recharging the batteries: 6 months
- A long term storage in open circuit leads to battery self discharge and deactivation of chemical components. It could be required to charge and discharge the batteries a few times to recover the initial performance.

3. Installation & commissioning

3.1 Activating NiCd batteries

When using rechargeable NiCd batteries for emergency lighting following point are essential in order to achieve the specified design life time of the batteries:

In order to activate new batteries, 2-3 full charging-discharging are needed to make sure batteries achieve their rated capacity. This activating process is defined by running 2-3 full charging (24 hrs) and discharging (1/2/3 hrs) cycles of the batteries. If this activation process is not conducted the emergency luminaire may not pass the initial duration test. If the first duration test fails, please repeat the test once again after a 24 hour charging period.

3.2 Avoidance of excessive cycling

During building installations, in many cases, mains supply is not available on a permanent 24-hour basis which then leads to unwanted, uncontrolled excessive battery cycles. This has a very strong effect on the design life time of the battery. Make sure that in such situations, the battery remains disconnected in the luminaire till the mains power supply is stable on a 24-hour basis. It is strongly recommended to refer to the datasheets of Tridonic emergency control gears to avoid excessive cycling. At the same time, make sure that this information is handed over to the installation staff / electrician in order to ensure a proper way of installation and commissioning.

3.3 Avoidance of deep-discharge conditions

It is very important that NiCd batteries are not left connected for long periods in a discharged state. Following options may lead to a deep discharge situation and must be avoided:

- Storage periods of rechargeable batteries of over 6 month without recharging the battery packs.
- Shipment, storage of assembled emergency luminaires with battery pack connected to the emergency driver.
- Long periods of mains-interruptions of more than two weeks, once, the emergency system is installed and the battery pack is connected to the emergency driver.

4. Mechanical details

4.1 Mechanical details for batteries with blade terminals

4.1.1 Battery leads

- Quantity: 1 red and 1 black
- Length: 1,300 mm
- Wire type: 0.5 mm² solid conductor
- Insulation temperature rating: 90 °C

4.1.2 Battery end termination

Push on 4.8 mm receptacle to suit battery soade fitted with insulating cover

4.1.3 Emergency lighting unit end termination

8.0 mm stripped insulation

Two-piece batteries are supplied with a 200 mm lead with 4.8 mm receptacles at each end and insulating covers to connect the separate sticks together. Connect two battery sticks in series by connecting plus to minus.

4.1.4 Batteries

Connection method: 4.8 x 0.5 mm spade tag welded to end of cell.

For stick packs this connection is accessible after the battery caps have been fitted.

To inhibit inverter operation disconnect the batteries by removing the connector from the battery spade tag.

4.2 Mechanical details for batteries with plug terminals

4.2.1 Battery leads

- Quantity: 1 red and 1 black with plug terminals
- Length: 1 m
- Battery connection: 0.1 m with connector
- Wire type: 0.5 mm² solid conductor
- Insulation temperature rating: 90 °C

4.2.2 Battery end termination

Plug terminals

4.2.3 Emergency lighting unit end termination

8.0 mm stripped insulation

4.2.4 Batteries

Connection method: 2-pole plug connection

To inhibit inverter operation disconnect the batteries by removing the connector from the battery spade tag.

5. Technical data Accu

Capacity			
Rated minimum capacity	1.6 Ah	4.2 Ah	4.5 Ah
Typical weight per cell	45 g	124 g	124 g
Cell dimensions			
Diameter	22.5 mm	32.5 mm	32.5 mm
Height	42.5 mm	60.5 mm	60.5 mm

Consult individual emergency control gear data sheet for maximum allowable temperatures and allowed number of discharge cycles.

6. Safety

- Do not short-circuit the battery pack – when installing the luminaire make sure sharp edges do not come into contact with cables.
- Do not open or damage the battery pack or throw it into a fire.
- Protect the battery against moisture and keep away from water.
- Do not expose the battery to direct sunlight or excessive heat (see storage conditions).
- Transport and store the battery only in its original packaging.
- Comply with the transport conditions of the transport company.
- Follow the instructions on the safety data sheets.



Damage/improper use

If the battery is damaged or user incorrectly vapours and liquids may escape from it. If you come into contact with battery fluid wash immediate with water and seek medical assistance if necessary.

7. Disposal

- Do not dispose of batteries with normal waste.
- Comply with local regulations when disposing of batteries.

8. Miscellaneous

8.1 Additional information

Additional technical information at www.tridonic.com → Technical Data

Guarantee conditions at www.tridonic.com → Services

Life-time declarations are informative and represent no warranty claim
No warranty if battery was opened.