

#### MSensor G3 SFI 30 PIR 5DPI WH/BK

Multi-sensor

#### Product description

- Sensor developed to work with the latest DALI specification
- Monitoring of ambient light and motion detection
- Remote control interface allowing infrared remote control interaction
- Individual adjustment of the parameters with configuration software
- Power supply via DALI line
- Shutter for preventing movement detection in one direction included
- Small dimensions allowing easy and inconspicuous integration in luminaries
- Wide range of accessories allowing extended application range
- 5-year guarantee

#### Housing properties

- Casing: PC polycarbonate, white or black
- Type of protection IP20

#### Note

- Tridonic MSensor G3 family sensors are developed according to DALI Standard EN 62386-101 Ed.2, also known as DALI-2.

To be able to use the sensor in such installation, an application controller is necessary.

List of approved application controller can be found on our WEB page „[Application controllers MSensor G3.pdf](#)“



Fig. 1



Fig. 2



**Standards**, page 5

**Wiring diagrams and installation examples**, page 6



### MSensor G3 SFI 30 PIR 5DPI WH/BK

Multi-sensor

#### Technical data

Supply via	DALI
Supply voltage	9.5 – 22.5 V
Current consumption (no LED)	max. 8 mA
Current consumption (with LED)	max. 9 mA
Mounting height	5 m
Mounting hole diameter	14.1 mm
Detection angle for PIR detection	84°
Detection angle for light measurement	30° – 60°
Detection range for light measurement <sup>①</sup>	0.5 – 2,000 lx
Min. temperature difference between ambient temperature and detected object	± 4 °C
Ambient temperature $t_a$	-20 ... +50 °C
$t_c$	60 °C
Storage temperature	-25 ... +60 °C
Type of protection	IP20

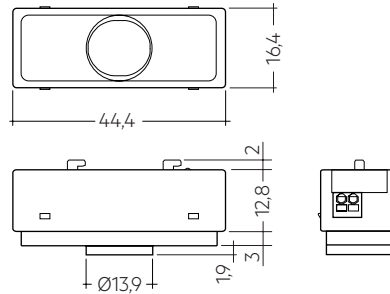

Fig. 1

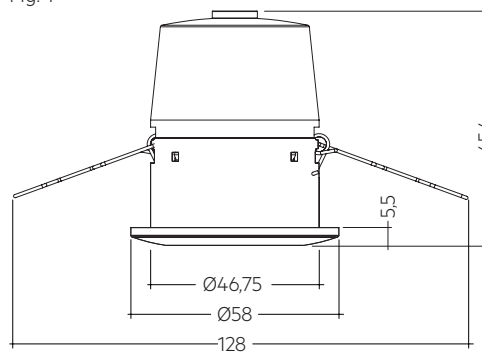

Fig. 2

#### Ordering data

Type	Article number	Figure	Colour	Dimension L x W x H	Packaging, carton	Weight per pc.
<b>MSensor G3 SFI 30 PIR 5DPI WH</b> Luminaire installation	<b>28002384</b>	1	White	44.4 x 16.4 x 19.7 mm	40 pc(s).	0.010 kg
<b>MSensor G3 SFI 30 PIR 5DPI BK</b> Luminaire installation	<b>28002385</b>	1	Black	44.4 x 16.4 x 19.7 mm	40 pc(s).	0.010 kg
<b>MSensor G3 SRC 30 PIR 5DPI WH</b> Ceiling installation	<b>28002386</b>	2	White	58 x 58 x 65.4 mm	10 pc(s).	0.037 kg

<sup>①</sup> The measured value at the sensor head corresponds to approx. 3 to 6,300 lux on the surface measured.

REMOTECONTROL IR6

**Product description**

- Optional infra-red remote control
- Switching on and off (On/Off button)
- Dimming (Up/Down button)
- Activation of automatic lighting control
- Setting the threshold control point (Set button)

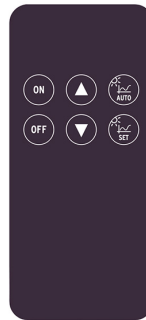

**Ordering data**

Type	Article number	Dimensions L x W x H	Packaging carton	Weight per pc.
REMOTECONTROL IR6	28000647	86.5 x 40.5 x 7.2 mm	500 pc(s).	0.019 kg

ACCES-  
SORIES

5DPI 14f Mounting Kit

**Product description**

- Mounting frame for attaching all 5DP 14f sensor directly to the luminaire housing
- Shutter for preventing movement detection in one direction
- Glow wire test with 750 °C according to EN 61347-1



**Ordering data**

Type	Article number	Packaging carton	Weight per pc.
5DPI 14f mounting kit	28001558	100 pc(s).	0.004 kg
5DPI 14f mounting kit black	28001575	100 pc(s).	0.004 kg

ACCES-  
SORIES

ACU Sensor Housing 14rs IP20

**Product description**

- Mounting frame for wired 5DP 14f sensors allowing direct mounting to the ceiling
- Easy „click in“ installation of the sensor
- IP20
- Casing: plastic, white
- UV stabilized plastic
- DALI MSensor 5DPI 14 is powered via DALI circuit, basicDIM DGC Sensor 5DPI 14f powered via control unit
- Optional shutter for reduction of movement detection area allowing to decrease the movement detection area from 360° to 240°
- Mounting kit with screws and decorative plugs
- 0.5 mm wiring for the sensor
- Two 3 x 1.5 mm<sup>2</sup> clamps with cable management (2 entry points on oppsite sides)
- Glow wire test with 750 °C according to EN 61347-1

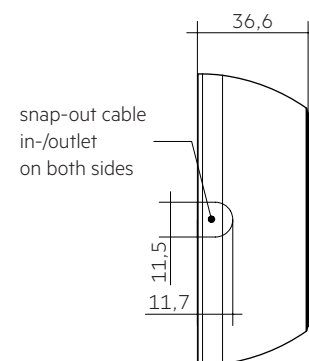
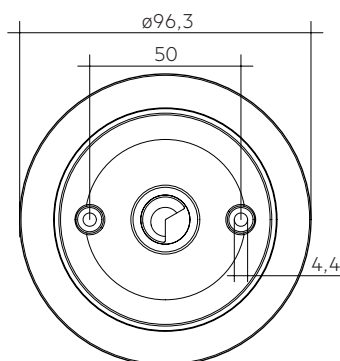

**Ordering data**

Type	Article number	Packaging carton	Weight per pc.
ACU Sensor Housing 14rs IP20	28001872	57 pc(s).	0.054 kg

## 1. Standards

EN/IEC 61347-2-11:2001  
EN 55015:2013  
EN 61000-3-2:2014 Part 3-2  
EN 61000-3-3:2013 Part 3-3  
EN 61547:2009  
EN 62386-101 Ed.2  
EN 62386-103 Ed.1  
EN 62386-301  
EN 62386-303  
EN 62386-304  
EN 62386-332

## 2. Common

MSensor G3 SFI 30 PIR 5DPI WH/BK is one of the new generation of Tridonic sensors.

With this Sensor, the customer gets a small sized sensor for low height applications and a protection against environmental influence up to IP20.

This sensor provides measurement of ambient light, motion detection via PIR sensor and IR remote control input as well as a RGB LED output for signalisation.

MSensor G3 SFI 30 PIR 5DPI WH/BK is created for following main applications:

Low height buildings such as

- Corridors, passages und Garages
- Office buildings

## 3. Installation

- The MSensor must not be connected to the mains. It is supplied directly via the DALI power supply.
- DALI is not SELV.  
The installation instructions for mains voltage therefore apply.
- Please ensure that the detection range of the sensor lies in the lighting area of the controlled luminaires.
- Please ensure that the detection ranges of the sensors do not overlap.  
This may have influence to the lighting control.
- When installed at a height other than the recommended installation height, the presence sensor might show different characteristics.  
When mounted at a higher level, its sensitivity is reduced.  
If mounted at a lower level, its range is reduced.
- Heaters, fans, printers and copiers located in the detection zone may cause incorrect presence detection.

### 1.1 DALI note



Tridonic MSensor G3 family sensors are developed according to DALI Standard EN 62386-101 Ed.2, also known as DALI-2.

To be able to use the sensor in such installation, an application controller is necessary.

List of approved application controller can be found on our WEB page „[Application\\_controllers\\_MSensor\\_G3.pdf](#)“

### 1.2 Glow wire test

according to EN 61347-2-11 passed for temperatures up to 850°C.

3.1 Wiring

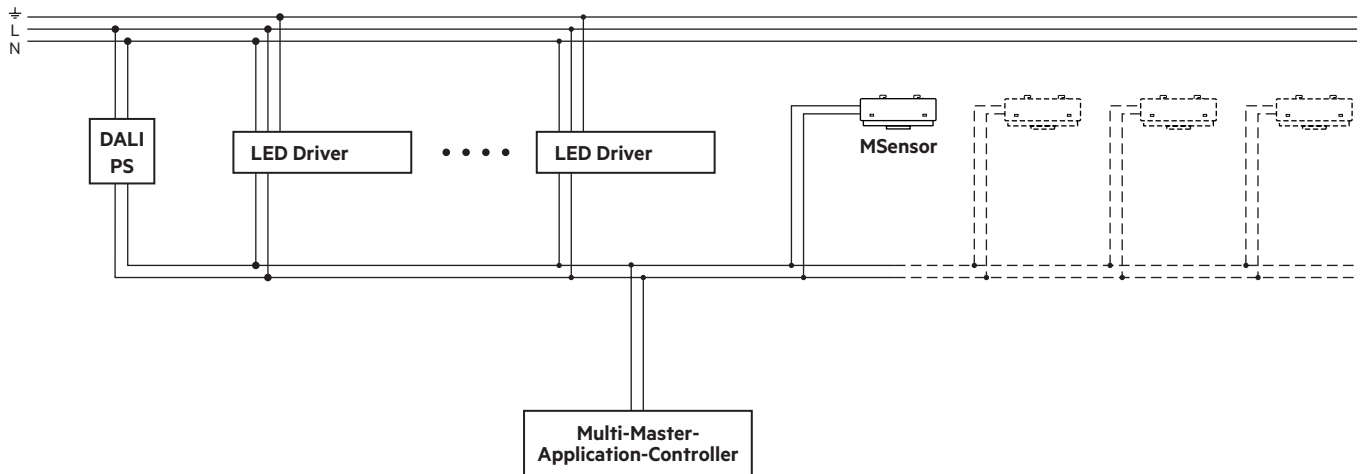

3.2 Wiring type and cross section for rc version

The wiring can be solid wire or stranded wire with a cross-section of 0.2 mm<sup>2</sup> to 1.5 mm<sup>2</sup>.

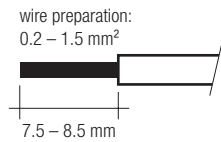

3.3 Wiring type and cross section for f version

The wiring can be solid wire or stranded wire with a cross-section of 0.2 mm<sup>2</sup> to 0.5 mm<sup>2</sup>.

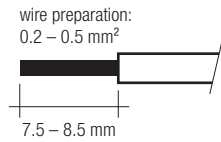

3.4 Mounting variants luminaire installation sensor:

Size of the sheet: 0.8 – 1.8 mm

Size of the sheet: 0.6 – 0.8 mm

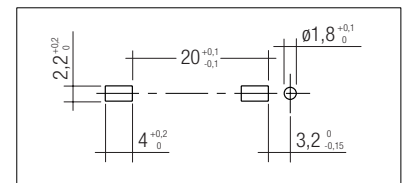
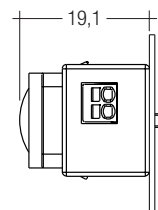
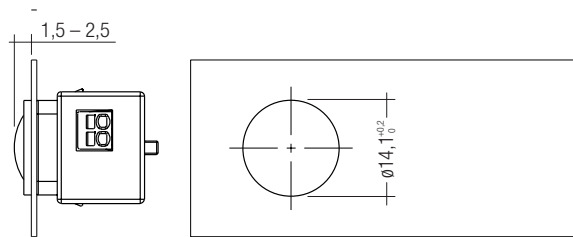

Size of the sheet: 0.8 – 3.0 mm

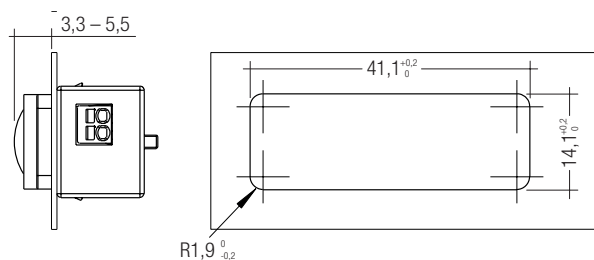

**3.5 Mounting in luminaire housing with Mounting Kit:**

Size of the sheet: 0.8 – 2.0 mm

Dimension drawing for needed mounting opening

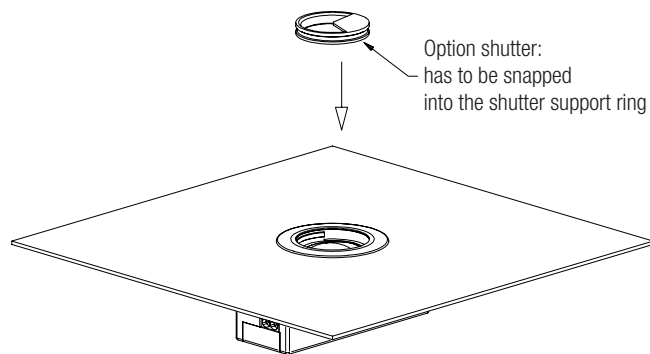
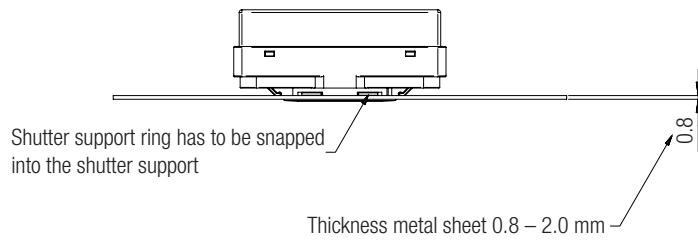
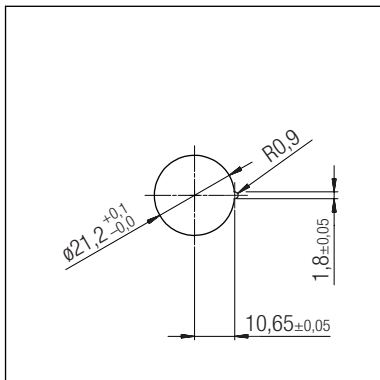

**3.6 Mounting Kit mounting**

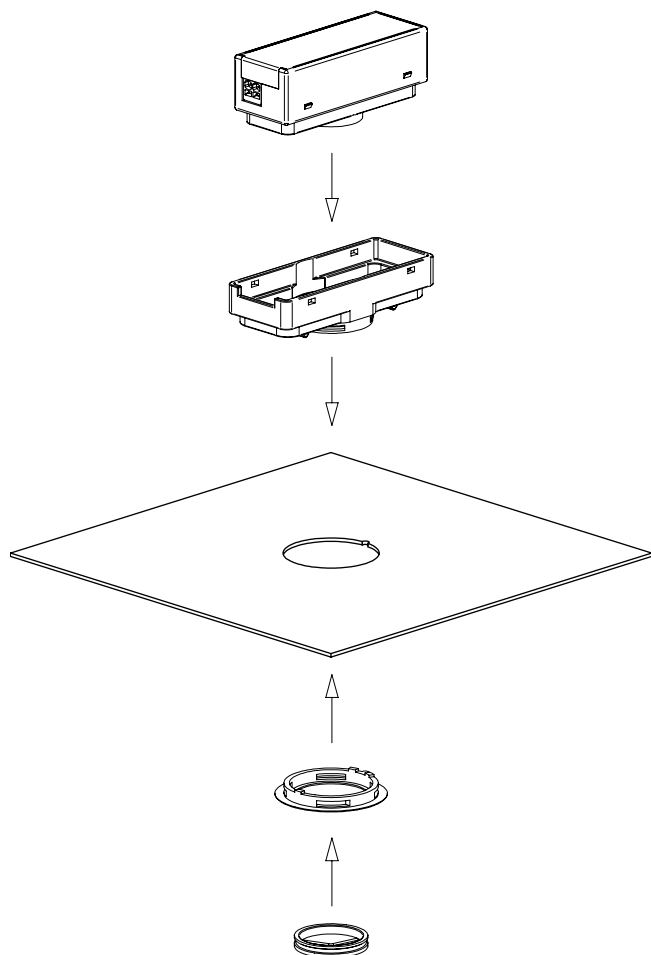

**3.7 Mounting Kit Shutter**

Area which is masked by the shutter.

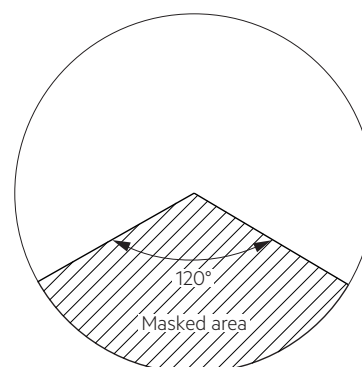
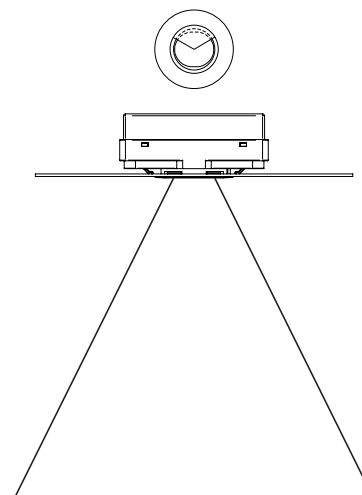

3.8 Wiring and mounting ACU Sensor Housing 14rs IP20

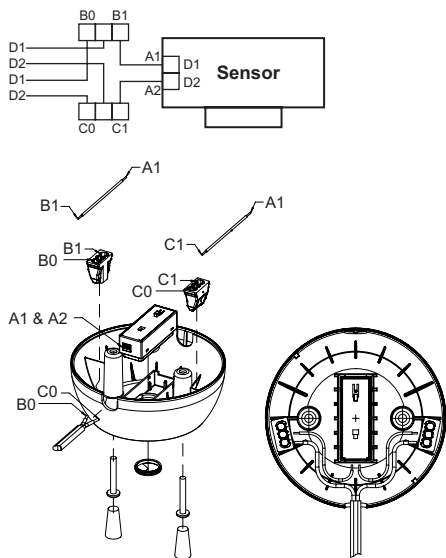

3.9 Mounting in class II luminaire

The Sensor provides basic insulation as required by IEC 62386-101 and defined in IEC 61347-1.

If the sensor is built in to a class II luminaire which has to provide double or reinforced insulation it has to be considered that the Sensor is not a class II device. Still the Sensor can be used for such projects as the front of the sensor is tested to fulfill the class II requirements for double or reinforced insulation.

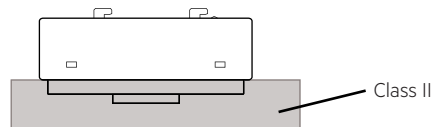

4. Light level recognition area

The measurement range is between 0.5 and 2000 lx. Measured at the sensor head.

**!** To be able to measure values < 5 lx in an accurate way it is needed to change integration time of light sensor to 800 ms. Integration time of light sensor is set to 100 ms by default. For values > 5 lx there is no difference in between these measurements.

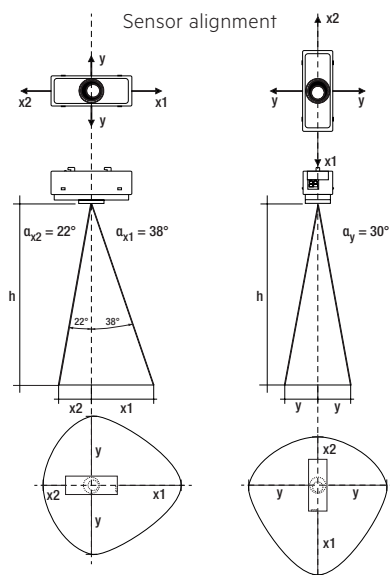

Example for light and motion detection area at height of 1.7 m:

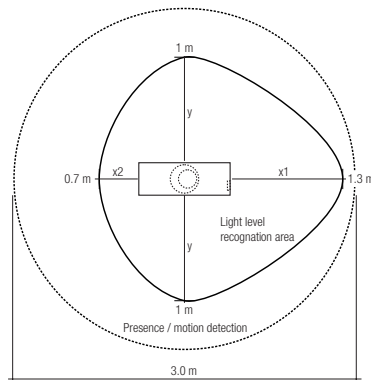

h *	x1	x2	y	d
1.7 m	1.3 m	0.7 m	1.0 m	3.0 m
2.0 m	1.6 m	0.8 m	1.2 m	3.6 m
2.3 m	1.8 m	0.9 m	1.3 m	4.1 m
2.5 m	2.0 m	1.0 m	1.4 m	4.5 m
2.7 m	2.1 m	1.1 m	1.6 m	4.9 m
3.0 m	2.3 m	1.2 m	1.7 m	5.4 m
3.5 m	2.7 m	1.4 m	2.0 m	6.3 m
4.0 m	3.1 m	1.6 m	2.3 m	7.2 m

\* The recommended maximum room height for office applications is 3 m and for corridor applications for example 4 m. Up to 2 m mounting height presence is detected and over 2 m motion is detected.

Calculation of the diameter (light area):

$$x1 = \tan(\alpha_{x1}) \times h$$

$$x2 = \tan(\alpha_{x2}) \times h$$

$$y = \tan(\alpha_y) \times h$$

Calculation of the diameter (motion area):

$$d = 2 \times \tan(0.5 \times \alpha) \times h$$



#### 4.1 Presence / motion detection

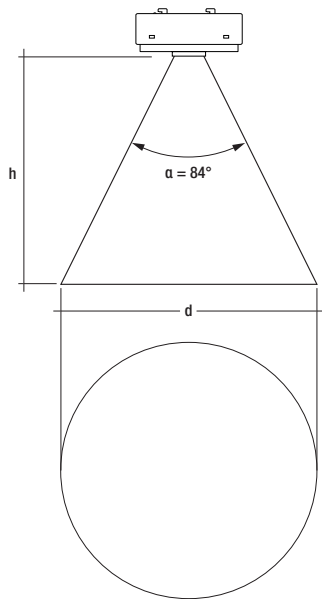

#### 4.2 Motion detection

For motion detection PIR technology is used. PIR Lens is made to detect moving people in working areas such as warehouses, storage buildings and similar working areas with the following performance criteria:

- Ceiling height from up to 5 m
- Movement of human body:
  - up to 2 m mounting height: detection of slight motion.
  - above 2 m mounting height: no slight motion (no sitting person) detection.
- Movement  $\geq 1.0$  m/s for mounting heights up to 5 m

#### 4.3 Status LED's

There is a LED built in with three different colours to indicate different status information to the user. This LED is controlled via DALI and from the sensor itself.



To not have any influence from LED to the light measurement, LED is disabled while light sensor is measuring by default.

The following operating modes can be set for lighting control via the mobile App configuration software:

Active	Constant light control is active.
Inactive	Constant light control is deactivated. The lighting is switched on an adjustable light value.

## 5. Miscellaneous

### 5.1 Additional information

Additional technical information at [www.tridonic.com](http://www.tridonic.com) → Technical Data

Guarantee conditions at [www.tridonic.com](http://www.tridonic.com) → Services

Life-time declarations are informative and represent no warranty claim.  
No warranty if device was opened.